



JOLLY MEC

design e tecnologia... andare oltre
design and technology... going beyond

P E L L E T





Dal 1968 siamo leader nella produzione di sistemi di riscaldamento domestico alimentati a biomassa.

Since 1968 we have been a leading enterprise in the production of biomass powered domestic heating systems.



INDICE - INDEX

“PLUS” PRODOTTI - *PRODUCT FEATURES*

p. 4



PELLET

V-SION

p. 12

PIXIE

p. 14

CHRISSIE

p. 16

CULT

p. 18

BOTERO 2

p. 20

ODETTE

p. 22

MELTEMI

p. 24

I-DEA 2 ANGOLO

p. 26

I-DEA 2 FRONTALE

p. 28

AMBRIA 2

p. 30

PADDY

p. 32

SYNTHESIS 60

p. 34

SYNTHESIS MODULAR

p. 36



PELLET

DUKA

p. 38

BRERA ACCIAIO

p. 40

BRERA MAIOLICA

p. 42

I-DEA ANGOLO IDRO

p. 44

I-DEA FRONTALE IDRO

p. 46

I-DEA QUADRA IDRO

p. 48

SYNTHESIS MODULAR IDRO

p. 50

J20 - J25

p. 52

J30 - J35

p. 54

CARATTERISTICHE TECNICHE

TECHNICAL SPECIFICATIONS

p. 56

DISEGNI TECNICI

TECHNICAL DRAWINGS

p. 66

... I dettagli che fanno la differenza
... *Details that make the difference*



Design pulito e raffinato. Senza griglia: ancora più bella.
Sleek and stylish design. Gridless: even more attractive.



Ampia visibilità della fiamma, oltre 40 cm.
Wide flame visibility, over 40 cm.

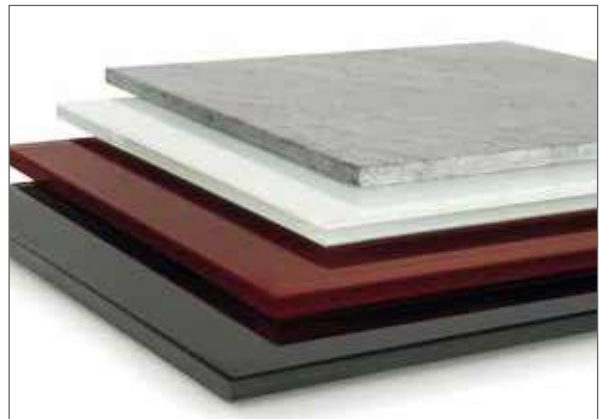

Pietra ollare sabbata, vetro temperato, ceramica e acciaio.
 Finiture moderne e curate nei dettagli.
*Sanded soapstone, tempered glass, ceramic and steel.
 Modern finishes and attention to detail.*



Stufa pulita.
 Tutti i comandi dal telecomando touch.
*Minimal design stove. Managed directly
 by a touch remote control.*



Vista panoramica della fiamma.
 Il fuoco su due o tre lati.
*Panoramic view of the flame.
 Fire on two or three sides.*



Installazione ordinata e pulita grazie all'uscita superiore, anche coassiale.
Neat and tidy installation thanks to the top output, also coaxial.

... Tecnologia avanzata
... *Advanced technology*



SISTEMA ERMETICO

Il sistema ermetico utilizza al 100% aria esterna e non preleva l'aria dall'ambiente. È collegabile direttamente con l'esterno e garantisce una corretta combustione del pellet senza alterare i ricambi di ossigeno all'interno dell'ambiente. Questo sistema fa della stufa un prodotto più efficiente e sicuro. Adatto soprattutto per le case passive.

AIRTIGHT SYSTEM

Airtight system taking 100% of combustion air from the outside, thus not taking air from the room. It connects directly to the outside and guarantees correct pellet combustion without altering the exchange of oxygen within the environment. This system makes the stove an efficient and safe product. Also suitable for passive houses.

DTA

Jolly Mec, sempre all'avanguardia ha ottenuto nel 2014 una certificazione molto importante, il DTA "Documento Tecnico di Applicazione". Il DTA è rilasciato dal CSTB, organismo nazionale francese di valutazione tecnica la cui missione è di assicurare la qualità e la sicurezza degli edifici. Il DTA ottenuto da Jolly Mec certifica l'ermeticità delle proprie stufe e l'installazione con le configurazioni possibili. Per questi modelli, i "kit uscita fumi" sono già montati in fabbrica: un importante risparmio di tempo per l'installatore, una stufa "pronta da collegare".

Constantly in the lead, Jolly Mec has obtained in 2014 a very important certification: the DTA "Technical Document of Application". The DTA is released by the CSTB, a French National Organism for Technical Evaluation whose mission is to assure the quality and safety of buildings. The DTA obtained by Jolly Mec certifies the air-tightness of the stoves and the installation with the possible configurations. For these models, the "kit for flue outlets" are already mounted in the production line: a real time-saver for the installer, a stove "ready to install".



USCITA FUMI POSTERIORE
REAR SMOKE OUTLET



USCITA FUMI SUPERIORE
UPPER SMOKE OUTLET



USCITA FUMI SUPERIORE COASSIALE
COAXIAL INTEGRATED UPPER SMOKE OUTLET

Le stufe a pellet Jolly-Mec sono fornite con kit di uscita fumi già montato per un'installazione semplificata. Per adattarsi alle diverse soluzioni abitative è possibile utilizzare l'uscita fumi più adatta.

The Jolly-Mec pellet stoves are equipped with smoke outlet kit already integrated for an easy installation. It is possible to use the suitable smoke outlet to adapt to the several housing solutions.

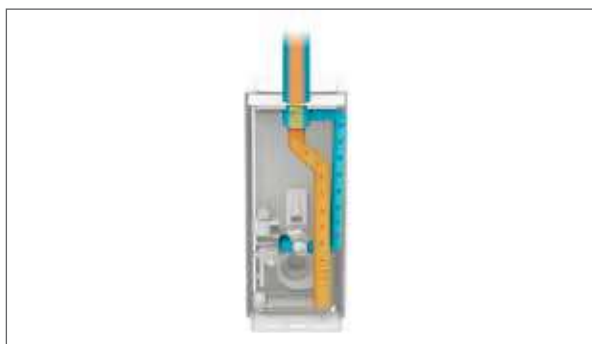

CANNA FUMARIA COASSIALE

L'installazione con canna fumaria coassiale è ideale per gli edifici passivi e a basso consumo energetico. L'aria di combustione ed i fumi vengono introdotti separatamente in un unico canale evitando la presa d'aria in parete. L'uscita superiore consente inoltre un risultato d'installazione più preciso ed ordinato.

COAXIAL FLUE

The installation with a coaxial flue is ideal for low energy consumption passive buildings. The combustion air and flue gas are introduced separately into a single flue. In addition, the top output makes it possible to achieve a more accurate and neater installation.



CONTROLLO COASSIALE

Assicura l'ottimizzazione di combustione e alte performance indipendentemente dalla configurazione di installazione.

COAXIAL CONTROL

It optimizes combustion and performances according to the configuration of the installation.



RESISTENZA AL QUARZO

Sicurezza e rapidità di accensione del pellet. Risparmio energetico e maggiore durata della resistenza.

QUARTZ IGNITION ELEMENT

Safe and rapid pellet ignition Energy savings and longer duration.



VALVOLA DI SICUREZZA

Serenità di utilizzo.

SAFETY VALVE

Ease of use.



FUNZIONE SILENT

Permette alla stufa di funzionare in modo silenzioso.

SILENT FUNCTION

Allows the stove to run silently with no noise impact.



IL DISPOSITIVO WIFI

Permette di comunicare con il sistema e gestire il funzionamento anche fuori casa.

THE WI-FI DEVICE

Allows you to communicate with your stove and manage its function even when you are away from home.

Canalizzazioni Ducting



Un vero impianto di riscaldamento; con la stufa canalizzabile è possibile riscaldare l'intera abitazione in modo uniforme e alla temperatura desiderata.

Ducting a stove can be useful for optimizing the circulation of heat in other rooms.

The range has been designed to have high ducting performance.



MELTEMI



I-DEA 2



BOTERO 2 - CHRISSIE - ODETTE - PADDY



SYNTHESIS MODULAR

Versione ad Aria

Air Version



CALORE IMMEDIATO

Un impianto ad aria consente di riscaldare l'intera abitazione grazie a canalizzazioni che non richiedono lavori di muratura. L'impianto ad aria ha il vantaggio di poter riscaldare rapidamente le stanze nelle quali si è canalizzata l'aria ed è pertanto l'ideale per seconde case o per integrare un impianto idraulico a caldaia preesistente.

INSTANT HEAT

An air system can heat the whole house using the ducting system that requires no masonry works. The air system has the advantage of providing instant heat to the rooms where the air is ducted, and is the ideal solution for holiday homes or in addition to an existing boiler heating system.



UMIDIFICATORE INCORPORATO

La presenza di umidificatore incorporato migliora la qualità dell'aria e assicura un ambiente più salutare. Basta aggiungervi poche gocce della vostra essenza preferita per profumare tutta la casa.

BUILT-IN HUMIDIFIER

The built-in humidifier improves the quality of the air and ensure a more healthy environment. Simply add a few drops of scent to diffuse your favourite fragrance throughout your home.

Versione ad Acqua

Water Version



CALORE OMOGENEO IN TUTTA LA CASA

Il termocamino o la termostufa possono essere collegati all'impianto di riscaldamento nuovo o già esistente e riscaldare autonomamente l'acqua calda dell'impianto a termosifoni o a bassa temperatura (a pavimento, a zoccolino ecc). Possono anche lavorare in parallelo con una eventuale caldaia pre-esistente, accumulatori e pannelli solari.

EVEN HEATING EVERYWHERE IN THE HOUSE

The heating fireplace or stove is connected to the new or to the existing heating system and heats the entire house independently, by means of radiators or a low-temperature system (floor heating, skirting board heating etc). They can also work in parallel with an existing boiler, accumulators and solar panels.

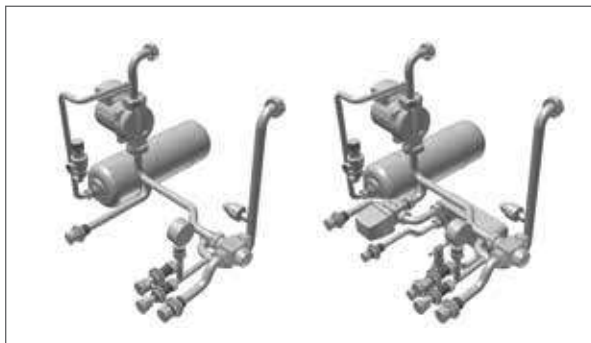

KIT IDRAULICO

Il kit idraulico a vaso chiuso, già assemblato e collaudato, è completo di valvole di sicurezza, pompa per il riscaldamento a basso consumo energetico, vaso di espansione.

PLUMBING KIT

It is supplied with a closed tank, already assembled and tested, complete with safety valves, heating pump with low energy consumption, expansion tank and anti-condensation valve.



VERSIONE COMFORT

Nella versione COMFORT è possibile riscaldare l'ambiente con la sola aria calda.

COMFORT VERSION

In the COMFORT version, it is possible to heat the room using hot air only.

V-SION



8 kW

Una stufa a pellet panoramica, caratterizzata da design esclusivo, linee essenziali e visione integrale della fiamma. V-SION nasce dall'incontro fra tecnologia avanzata ed esperienza sensoriale. La porta trifacciale in vetro ceramico permette di godere di tutto il fascino del fuoco. Un prodotto dalle linee minimaliste in grado di conferire all'ambiente un'aura esclusiva. La tecnologia innovativa permette di ottenere alti rendimenti a basse emissioni; tutti componenti sono full 24 volt, inoltre è compatibile con batteria di mantenimento e sistema di ricarica per funzionare anche in caso di black-out. V-SION è ideata e certificata per funzionare in modo ermetico: in questo modo l'aria per la combustione viene prelevata dall'esterno senza sottrarre ossigeno nell'ambiente interno. Per adattarsi alle diverse soluzioni abitative è possibile utilizzare l'uscita fumi più adatta; posteriore o superiore. Installabile anche con canna fumaria coassiale. È possibile includere un kit di canalizzazione, per poter riscaldare gli ambienti circostanti. Tutti i comandi possono essere eseguiti tramite la semplice interfaccia del radiocomando touch di serie. Il dispositivo Wifi garantisce il funzionamento della stufa a distanza tramite web app, dal proprio smartphone o tablet.

A wide-screen pellet stove with an exclusive design, clean lines and full flame view. V-SION comes from the match between advanced technology and sensory experience. The three-side ceramic glass door allows to fully enjoying the charm of the flame. A product with a minimalist design able to give an exclusive atmosphere to the room. The innovative technology allows to obtain high efficiency and low emissions; all components are full 24 volts, furthermore, the stove is compatible with trickle battery and recharging system so to work even in the event of a black out. V-SION is designed and certified to work hermetically: the combustion air is taken from the outside without taking oxygen from the room. V-SION can fit in various living arrangements by choosing the most suitable smoke output configuration: rear or upper. It can also be installed with coaxial smoke output. It is also possible to add a ducting kit to heat other rooms nearby. All commands are managed with the included touch remote control. Wi-Fi device manages the stove from smartphone or tablet by using the specific App.





PIXIE



PELLET



ARIA
AIR

7 kW

Una reinterpretazione in chiave moderna di un grande classico, PIXIE è il perfetto connubio fra tradizione ed innovazione. Le cure nei dettagli e le dimensioni contenute ne fanno un vero e proprio bijou d'arredo, in grado di inserirsi in modo armonioso per valorizzare qualsiasi ambiente. L'eleganza del rivestimento in ceramica e il vetro nero temperato contribuiscono ad esaltare il fascino della fiamma. La tecnologia innovativa permette di ottenere alti rendimenti a basse emissioni, garantendo la migliore performance classificata 5 stelle (DM 186/2017). PIXIE è ideata e certificata per funzionare in modo ermetico: in questo modo l'aria per la combustione viene prelevata dall'esterno senza sottrarre ossigeno nell'ambiente interno. Per adattarsi alle diverse soluzioni abitative è possibile utilizzare l'uscita fumi più adatta; posteriore o superiore. Installabile anche con canna fumaria coassiale. Tutti i comandi possono essere eseguiti tramite la semplice interfaccia del radiocomando touch di serie. Il dispositivo Wifi garantisce il funzionamento della stufa a distanza tramite web app, dal proprio smartphone o tablet.

A modern reinterpretation of a timeless classic. PIXIE is the perfect combination between tradition and innovation. Its care for details and small size makes it a real bijou of furniture, able to harmoniously fit in and enhance every room. The elegance of the ceramic cladding with black tempered glass top help to bring the charm of the flame out. The breakthrough technology allows high efficiency and low emissions.

PIXIE is designed and certified to work hermetically: the combustion air is taken from the outside without taking oxygen from the room. PIXIE can fit in various living arrangements by choosing the most suitable smoke exits configuration: rear or upper. It can also be installed with coaxial smoke exits.

All commands are managed with the included touch remote control. Wi-Fi device manages the stove from smartphone or tablet by using the specific App.



COLORI COLOURS



CERAMICA BIANCA E
TOP VETRO NERO
WHITE CERAMIC AND
BLACK GLASS TOP



CERAMICA NERA E
TOP VETRO NERO
BLACK CERAMIC AND
BLACK GLASS TOP



CHRISSIE



PELLET



ARIA
AIR

6 kW

La sua forma snella e slanciata, abbinata ad un design pulito e senza griglie tradizionali a vista, rende la stufa a pellet CHRISSIE una vera icona di bellezza, oltre a racchiuderne tutta la tecnologia avanzata di Jolly Mec. È caratterizzata da un ampio vetro frontale che gestisce una spettacolare visione della fiamma. Puoi scegliere tra finiture moderne come il vetro temperato nelle colorazioni bianco, nero o bordeaux e la pietra ollare sabbata.

Its minimal shape, combined with a neat design featuring concealed conventional grids, makes the CHRISSIE pellet stove an attractive icon of beauty, while exploiting the state-of-the-art technology shows by Jolly Mec. It is characterised by a wide front window that shows a spectacular view of the flame. You can also choose from a number of modern finishes such as tempered glass in white, black or bordeaux and sanded soapstone.



COLORI COLOURS



VETRO BIANCO
WHITE GLASS



VETRO BORDEAUX
BORDEAUX GLASS



VETRO NERO
BLACK GLASS



PIETRA OLLARE
SOAPSTONE



CULT



PELLET



ARIA
AIR

8 kW

CULT è una stufa tonda, dalle linee graziose senza griglie tradizionali a vista. CULT ha un design moderno, è compatta e potente ed è ideale per riscaldare abitazioni di medie dimensioni. È caratterizzata da una porta in doppio vetro ed è disponibile in due diverse finiture, acciaio bianco o acciaio nero.

Prevista con l'uscita fumi superiore semplice per risparmiare spazio, CULT potrà inoltre essere installata anche con l'uscita fumi posteriore (in opzione).

CULT is a round stove with elegant lines. CULT has a modern design, it is compact, powerful and ideal for heating medium-sized houses. Black or white steel cladding, double glass door.

Provided with a simple upper smoke outlet to save space, CULT can also be installed with the rear smoke outlet (optional). The tank has been designed to hold a bag of 15 kg pellets.



COLORI COLOURS



ACCIAIO BIANCO
E ACCIAIO NERO
WHITE STEEL
AND BLACK STEEL



ACCIAIO NERO
BLACK STEEL



BOTERO 2



PELLET



ARIA
AIR

8 kW

10 kW

Elegante e raffinata, senza griglie tradizionali a vista, la stufa a pellet BOTERO 2 racchiude tutta la tecnologia avanzata di Jolly Mec. È fornita full optional con incorporato di serie l'umidificatore ed il dispositivo Wi-Fi che permette di gestirne il funzionamento anche da fuori casa. Puoi scegliere la finitura più idonea al tuo ambiente, dal vetro temperato nelle colorazioni bianco, nero, bordeaux, reflex bronzo o vetro nero rigato o la pietra ollare sabbata.

Stylish and refined, without visible conventional grids, the BOTERO 2 pellet stove encompasses all the state-of-the-art technology boasted by Jolly Mec. It is supplied in a full optional version with standard features such as the humidifier and the Wi-Fi device, allowing users to control the system when away from home. You can also choose the finish which best suits for your house, from tempered glass in white, black, bordeaux, reflex bronze or striped black glass to sanded soapstone.

COLORI COLOURS



VETRO BIANCO
WHITE GLASS



VETRO REFLEX BRONZO
BRONZE REFLEX GLASS



VETRO NERO
BLACK GLASS



VETRO NERO
RIGATO "STRIP"
STRIPED BLACK
GLASS "STRIP"



VETRO BORDEAUX
BORDEAUX GLASS



PIETRA OLLARE
SOAPSTONE



ODETTE



6 kW *

8 kW

10 kW

La linea pulita e decisa ed il frontale senza griglie tradizionali a vista, rendono ODETTE una stufa a pellet dal design ricercato. Grazie all'ampia proposta di potenze di riscaldamento, ODETTE è molto versatile ed adatta a qualsiasi ambiente. Puoi scegliere tra finiture moderne e curate come il vetro temperato nelle colorazioni bianco, nero, bordeaux o la pietra ollare sabbiata.

The neat and bold lines and the front with the concealed conventional grids, make ODETTE a pellet stove with an exceptional design. The outstanding range of heating outputs make ODETTE very versatile and ideal for all environments. You can also choose from a number of modern and sleek finishes such as tempered glass in white, black, bordeaux to sanded soapstone.



COLORI COLOURS



VETRO BIANCO
WHITE GLASS



VETRO BORDEAUX*
BORDEAUX GLASS*

Solo per ODETTE 6 kW
Only for ODETTE 6 kW



VETRO NERO
BLACK GLASS

Solo per ODETTE 8-10 kW
Only for ODETTE 8-10 kW



PIETRA OLLARE
SOAPSTONE

* Prodotti disponibili fino ad esaurimento scorte
* Until stock last



MELTEMI



PELLET



ARIA
AIR

12 kW

14 kW

Potenza, performance e linee maestose. MELTEMI presenta molteplici aspetti.

Disponibile in 2 potenze, 12 e 14 kW, MELTEMI soddisfa la richiesta di potenza in grandi volumi. Una linea unica e compatta (solo 45 cm di profondità). Pochi e semplici comandi per controllare tutte le funzioni della stufa. MELTEMI presenta frontalmente una griglia verticale dell'aria, regolabile e orientabile. Può essere installata con l'uscita posteriore o con l'uscita superiore semplice o concentrica. Infine MELTEMI può canalizzare l'aria nelle altre stanze, con o senza ventilatore.

Power, performance and majestic lines. MELTEMI presents multiple aspects.

Available in 2 powers, 12 and 14 kW, MELTEMI satisfies the demand for power in large volumes. A single and compact line (only 45 cm deep). Few and simple controls to manage all the functions of the stove. MELTEMI has frontally a vertical and adjustable air grid. It can be installed with the rear outlet or with the simple or coaxial upper outlet. Finally MELTEMI can duct the air to the other rooms, with or without fan.



COLORI COLOURS



ACCIAIO E
MAIOLICA BIANCO
WHITE STEEL
AND CERAMIC



PIETRA OLLARE
SOAPSTONE



ACCIAIO E MAIOLICA NERO
BLACK STEEL
AND CERAMIC



I-DEA 2 ANGOLO



PELLET



ARIA
AIR

10 kW

I-DEA 2 ANGOLO racchiude tutta la tecnologia avanzata di Jolly Mec e con la sua ridotta profondità di soli 27 cm si presta per essere collocata facilmente in ogni ambiente. Lo stile moderno, la mancanza di griglie tradizionali a vista ed il design ricercato si completano con la bellezza dell'ampio vetro angolare che permette un'ampia visibilità della fiamma. È fornita full optional con incorporato di serie l'umidificatore ed il dispositivo Wi-Fi che permette di gestire il funzionamento anche da fuori casa. Puoi scegliere la cornice esterna in acciaio nelle colorazioni nero, bianco e tortora, come pure il pannello frontale, sempre a scelta, tra il gres avorio o ruggine, la pietra ollare sabbata, il vetro temperato nero rigato, l'acciaio nero. Grazie a studi approfonditi del reparto di progettazione e ricerca e sviluppo, la stufa I-DEA 2 ANGOLO può essere installata con l'uscita superiore coassiale. I-DEA 2 ANGOLO ad oggi è proposta in 3 versioni di installazione: uscita posteriore (semplice o coassiale), uscita superiore semplice e in uscita superiore coassiale.

I-DEA 2 ANGOLO encompasses all Jolly Mec's state-of-the-art technology, and its slim depth of just 27 cm means it can be easily installed in any house. Its modern style, without visible conventional grids and superior design are enhanced by the beauty of the wide corner glass window with ample flame visibility. It is supplied in a full optional version with standard features such as the humidifier and the Wi-Fi device, allowing users to control the system when away from home. You can choose the external profile in black, white or dove grey steel, the front panel in ivory, rust, sanded soapstone, striped black tempered glass and black steel. Thanks to in-depth studies of the design and research and development department, the I-DEA 2 ANGOLO stove can be installed with the coaxial smoke outlet. I-DEA 2 ANGOLO to date is offered in 3 installation versions: rear exit (simple or coaxial) simple upper exit and in coaxial upper exit.



PROFILO PROFILE COLOUR



BIANCO
WHITE



NERO
BLACK



TORTORA
DOVE GREY

PANNELLO FRONTALE FRONT PANEL



GRES AVORIO
IVORY GRES



ACCIAIO GRIGIO
TORTORA
DOVE GREY
STEEL



ACCIAIO NERO
BLACK STEEL

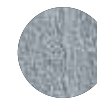

PIETRA OLLARE
SOAPSTONE



GRES RUGGINE
RUST GRES

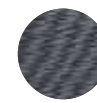

VETRO NERO
RIGATO
STRIPED BLACK
GLASS



I-DEA 2 FRONTALE



PELLET



ARIA
AIR

10 kW

I-DEA 2 FRONTALE racchiude tutta la tecnologia avanzata di Jolly Mec e con la sua ridotta profondità di soli 27 cm si presta per essere collocata facilmente in ogni ambiente. Lo stile moderno, la mancanza di griglie tradizionali a vista ed il design ricercato si fondono con la porta tutta vetro che permette un'ampia visibilità della fiamma. È fornita full optional con incorporato di serie l'umidificatore ed il dispositivo Wi-Fi che permette di gestirne il funzionamento anche da fuori casa. Puoi scegliere la cornice esterna in acciaio nelle colorazioni nero, bianco e tortora, come pure il pannello frontale, sempre a scelta, tra il gres avorio o ruggine, la pietra ollare sabbata, il vetro temperato nero rigato, l'acciaio nero. Grazie a studi approfonditi del reparto di progettazione e ricerca e sviluppo, la stufa I-DEA 2 FRONTALE può essere installata con l'uscita superiore coassiale. I-DEA 2 FRONTALE ad oggi è proposta in 3 versioni di installazione: uscita posteriore (semplice o coassiale), uscita superiore semplice e in uscita superiore coassiale.

I-DEA 2 FRONTALE encompasses all Jolly Mec's state-of-the-art technology, and its slim depth of just 27 cm means it can be easily installed in any house. Its modern style, without visible conventional grids and superior design are enhanced by the complete glass door with ample flame visibility. It is supplied in a full optional version with standard features such as the humidifier and the Wi-Fi device, allowing users to control the system when away from home. You can choose the external profile in black, white or dove grey steel, the front panel in ivory, rust, sanded soapstone, striped black tempered glass and black steel. Thanks to in-depth studies of the design and research and development department, the I-DEA 2 FRONTALE stove can be installed with the coaxial smoke outlet. I-DEA 2 FRONTALE to date is offered in 3 installation versions: rear exit (simple or coaxial) simple upper exit and in coaxial upper exit.



PROFILO PROFILE COLOUR



BIANCO
WHITE



NERO
BLACK



TORTORA
DOVE GREY

PANNELLO FRONTALE FRONT PANEL



GRES AVORIO
IVORY GRES



ACCIAIO GRIGIO
TORTORA
DOVE GREY
STEEL



ACCIAIO NERO
BLACK STEEL

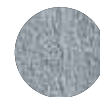

PIETRA OLLARE
SOAPSTONE



GRES RUGGINE
RUST GRES



VETRO NERO
RIGATO
STRIPED BLACK
GLASS



AMBRIA 2



6 kW

8 kW

10 kW

La stufa a pellet AMBRIA 2 si caratterizza per il design essenziale, pulito e per l'alta prestazione nel riscaldamento. La stufa a pellet AMBRIA 2 è rifinita in acciaio nero con particolari a scelta nelle colorazioni nero o bianco. Disponibile in 3 diverse potenze: 6 kW, 8 kW e 10 kW.

The AMBRIA 2 pellet stoves boasts a minimal design and high heating performance. The AMBRIA 2 pellet stoves comes with a black steel finish and details in a colour of your choice from black or white. Available in 3 different powers: 6 kW, 8 kW and 10 kW.



COLORI COLOURS



BIANCO
WHITE



NERO
BLACK



PADDY



PELLET



ARIA
AIR

6 kW

8 kW

10 kW

PADDY è una stufa moderna, di carattere senza le tradizionali griglie frontali a vista. È proposta in 3 potenze, 6 kW, 8 kW e 10 kW e in 3 finiture, acciaio nero, bianco o bordeaux. PADDY è ideale per riscaldare abitazioni di medie dimensioni adattandosi perfettamente in tutti gli ambienti di casa con la possibilità di canalizzare l'aria calda in altre stanze (opzionale).

PADDY può essere installata con l'uscita fumi posteriore oppure superiore semplice.

PADDY is a modern stove, with character. It is available 3 powers, 6 kW, 8 kW and 10 kW, in 3 finishes, black, white or burgundy steel. It heats medium-sized houses and adapts perfectly to all home environments with the possibility of spreading the hot air to other rooms (optional).

Trendy stove, PADDY can be installed with the rear or upper simple smoke outlet.



COLORI COLOURS



ACCIAIO
E MAIOLICA BIANCO
WHITE STEEL
AND CERAMIC



ACCIAIO E MAIOLICA
BORDEAUX
BORDEAUX STEEL
AND CERAMIC



ACCIAIO
E MAIOLICA NERO
BLACK STEEL
AND CERAMIC



SYNTHESIS 60



PELLET



ARIA
AIR

7 kW

Termocamino a pellet compatto e performante, adatto sia per nuove realizzazioni che per dare nuova vita al focolare esistente. Le dimensioni contenute e il design pulito lo rendono ideale per il riscaldamento di piccoli e medi ambienti, tramite aria forzata. Il pratico sportello frontale in vetro a ribalta copre il cassetto del carico pellet; pochi e semplici passaggi permetteranno di caricare il contenitore senza dover spegnere il caminetto. La tecnologia innovativa permette di ottenere alti rendimenti a basse emissioni, garantendo la migliore performance classificata 5 stelle (DM 186/2017). SYNTHESIS 60 è ideato e certificato per funzionare con sistema ermetico: in questo modo l'aria per la combustione viene prelevata dall'esterno senza sottrarre ossigeno nell'ambiente interno. Per adattarsi alle diverse soluzioni abitative, SYNTHESIS 60 è installabile anche con canna fumaria coassiale. Tutti i comandi possono essere eseguiti tramite la semplice interfaccia del radiocomando touch di serie. Il dispositivo Wifi garantisce il funzionamento del termocamino a distanza tramite la web app, dal proprio telefono o tablet.

The compact and high-performing insert, suited both to new installations as well as to giving a new life to the existing fireplace. The small size and clean design make it ideal for the heating by forced air of small-to-medium size rooms. The practical front-flap glass-door covers the pellet-loading drawer; a few simple steps will allow to loading the tank without having to turn off the fireplace.

SYNTHESIS 60 is designed and certified to work hermetically: the combustion air is taken from the outside without taking oxygen from the room. To fit in various living arrangements, SYNTHESIS 60 can also be installed with coaxial smokes exhaust. All commands are managed with the included touch remote control. Wi-Fi device manages the stove from smartphone or tablet by using the specific App.



CONFIGURAZIONE INSERTO
INSERT CONFIGURATION



CONFIGURAZIONE CAMINETTO
FIREPLACE CONFIGURATION



SYNTHESIS MODULAR



PELLET



ARIA
AIR

9 kW

68

11,5 kW

80

SYNTHESIS MODULAR è l'innovativo focolare modulare a pellet ad aria forzata dal design pulito, senza griglie a vista e adatto alle installazioni più esigenti. Grazie ai componenti modulari SYNTHESIS MODULAR può essere fornito con diverse configurazioni: come inserto per camino esistente, con cassetto di caricamento pellet frontale (1) o caricamento dalla cappa con tubo orientabile e sportello (3) oppure come nuovo caminetto con l'aggiunta del cavalletto, sempre con la scelta del cassetto di caricamento pellet frontale (2) o con tubo orientabile e sportello (4). Le versioni con caricamento pellet dalla cappa con tubo orientabile possono essere corredate dalla riserva supplementare pellet (5 e 6) per una maggiore autonomia di gestione. Con SYNTHESIS MODULAR puoi decidere di canalizzare l'aria calda in altri locali, con o senza ventilatore aggiuntivo.

SYNTHESIS MODULAR is the essence of the air pellet fireplace, with an elegant design. SYNTHESIS MODULAR is complete with all possible accessories to be able to transform it according to your needs and requirements. From the simple interlocking insert in an existing fireplace, to the renewal and replacement of an old fireplace, SYNTHESIS MODULAR can become a new fireplace with or without stand and have multiple accessories such as: pellet loading, possible thanks to the front drawer or an adjustable tube; the diffusion of hot air, frontal or with the possibility of ducting air into other rooms; the pellet supply, with the classic reserve or with an additional tank. Discover the aesthetics and the different proposals of this model!

PER SYNTHESIS MODULAR 68
FOR SYNTHESIS MODULAR 68



SYNTHESIS MODULAR 68



SYNTHESIS MODULAR 80

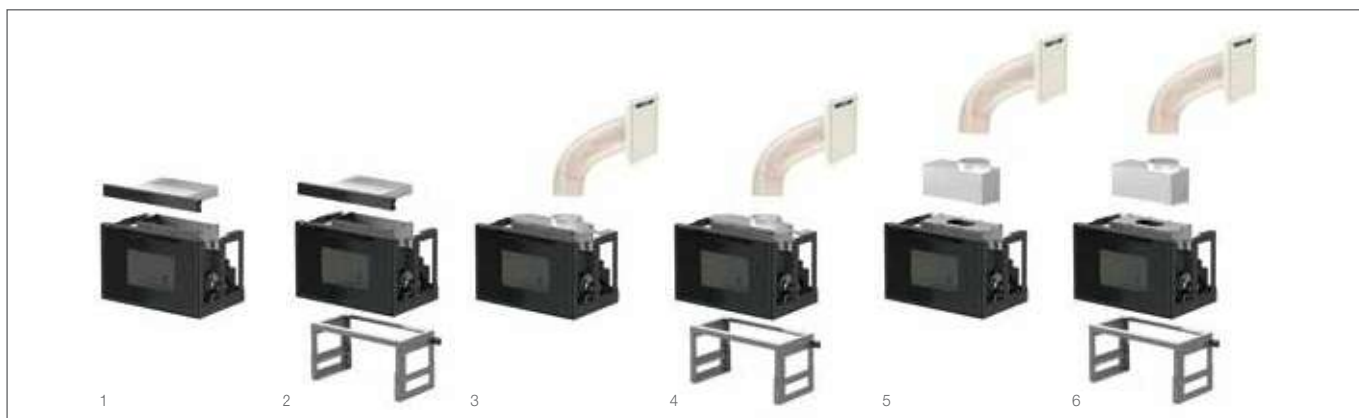

1. Inserto + cassetto di caricamento pellet
Insert + pellet loading drawer
2. Inserto + cassetto di caricamento pellet + cavalletto
Insert + pellet loading drawer + Basement
3. Inserto + tubo orientabile di caricamento pellet con sportello
Insert + adjustable pellet loading tube with door
4. Inserto + tubo orientabile di caricamento pellet con sportello + cavalletto
Insert + adjustable pellet loading tube with door + Basement
5. Inserto + riserva supplementare pellet + tubo orientabile di caricamento pellet con sportello
Insert + additional pellet reserve + adjustable pellet loading tube with door
6. Inserto + riserva supplementare pellet + tubo orientabile di caricamento pellet con sportello + cavalletto
Insert + additional pellet tank + adjustable pellet loading tube with door + Basement



Synthesis Modular è fornito di serie con l'uscita dell'aria calda frontale e relativa regolazione in uscita. È possibile canalizzare 1 o 2 bocchette (2 bocchette per mod 80) d'aria calda in altri locali senza ventilatore aggiuntivo (A). È prevista l'aggiunta di un ventilatore addizionale destro da 170 m³/h per una maggiore distanza (B).

Synthesis Modular is supplied as standard with frontal hot air outlet and relative output adjustment. It is possible to duct 1 or 2 (2 vents for mod 80) hot air vents into other rooms without an additional fan (A). The addition of an additional right 170 m³/h fan is foreseen for a greater distance (B).



DUKA



PELLET



ACQUA
WATER

16 kW

19 kW

Design esclusivo, linee pulite, alta efficienza caratterizzano la nuova termostufa DUKA.

DUKA è proposta in due potenze, 16 kW e 19 kW e in due finiture, bianco o nero. DUKA è ideale per riscaldare in modo autonomo medie-grandi abitazioni. Nella versione COMFORT è possibile riscaldare l'ambiente con la sola aria calda; dalla griglia verticale a sinistra della porta in vetro, il potente ventilatore e lo scambiatore permettono di riscaldare rapidamente l'ambiente senza attivare l'impianto. Pratica e facile da utilizzare, tutti i comandi di funzionamento e di regolazione avvengono tramite un radiocomando intuitivo fornito in serie. Il kit idraulico è fornito in serie ed è già collaudato. Inoltre, con il dispositivo wifi si può gestire il funzionamento della stufa e regolare la temperatura a distanza tramite telefono o tablet.

Exclusive design, clear lines, high efficiency characterize the new DUKA heating stove.

DUKA is available in two different powers ratings: 16 kW and 19 kW and in two colors, white or black.

DUKA is perfect for autonomous warming of medium-large houses. In the COMFORT version, it is possible to heat the room using hot air only; from the vertical grill on the left side of the glass door, the powerful fan and the heat exchanger give the possibility to warm the room quickly, without setting the system up.

Practical and easy to use, all operation and regulation controls can be done by using the equipped radio remote control. The hydraulic kit is also already given and already tried out. Moreover, using remote Wi-Fi system control, you can handle the functioning of the stove and regulate the temperature with a remote control using the smartphone or a tablet.

PER DUKA 19
FOR DUKA 19



COLORI
COLOURS



ACCIAIO BIANCO
WHITE STEEL



ACCIAIO NERO
BLACK STEEL



BREERA ACCIAIO



PELLET



ACQUA
WATER

20 kW

24 kW

28 kW

Un vero impianto di riscaldamento. La stufa idro BREERA ACCIAIO è pensata per riscaldare l'intera abitazione e produrre acqua calda sanitaria. Le alte prestazioni, la versatilità e le caratteristiche costruttive di Brera la rendono unica nel suo genere. È fornita in tre versioni: la versione standard per il riscaldamento dei termosifoni e acqua sanitaria, la versione con "ventilazione basic" che oltre a riscaldare i termosifoni e l'acqua sanitaria riscalda anche con aria calda il locale in cui è installata la stufa velocizzando i tempi di riscaldamento, e la versione con l'innovativo "sistema comfort" che oltre a riscaldare i termosifoni ed acqua sanitaria permette di riscaldare il locale stufa solo con aria calda escludendo l'impianto ad acqua, ideale per le mezze stagioni e per gli impianti a bassa temperatura prima dell'accensione dell'impianto generale. Puoi scegliere la finitura di BREERA tra l'acciaio con top in maiolica e tutta maiolica, entrambe nelle colorazioni bianco, nero e bordeaux.

A true heating system. The BREERA ACCIAIO hydro stove is designed to heat the entire house and produce domestic hot water. Its high performances, versatility and structural characteristics make it one of a kind. It is available in three versions: the standard one to heat radiators and domestic water; the version with 'basic ventilation' which doesn't only heat radiators and domestic water but also the room where it is installed through hot air; and lastly the version with the 'comfort system' which allows to benefit only of the air heating, ideal for the mid-season periods and for low temperature systems before turning on the central heating system. You can choose between two finishes: steel with ceramic top or full ceramic, both in the colors white, black or bordeaux.

COLORI COLOURS



ACCIAIO E MAIOLICA
BIANCO
WHITE STEEL
AND CERAMIC



ACCIAIO E MAIOLICA
BORDEAUX
BORDEAUX STEEL
AND CERAMIC



ACCIAIO
E MAIOLICA NERO
BLACK STEEL
AND CERAMIC



BRERA MAIOLICA



PELLET



ACQUA
WATER

20 kW

24 kW

28 kW

Un vero impianto di riscaldamento. La stufa idro BRERA MAIOLICA è pensata per riscaldare l'intera abitazione e produrre acqua calda sanitaria. Le alte prestazioni, la versatilità e le caratteristiche costruttive di Brera la rendono unica nel suo genere. È fornita in tre versioni: la versione standard per il riscaldamento dei termosifoni e acqua sanitaria, la versione con "ventilazione basic" che oltre a riscaldare i termosifoni e l'acqua sanitaria riscalda anche con aria calda il locale in cui è installata la stufa velocizzando i tempi di riscaldamento, e la versione con l'innovativo "sistema comfort" che oltre a riscaldare i termosifoni ed acqua sanitaria permette di riscaldare il locale stufa solo con aria calda escludendo l'impianto ad acqua, ideale per le mezze stagioni e per gli impianti a bassa temperatura prima dell'accensione dell'impianto generale. Puoi scegliere la finitura di BRERA tra l'acciaio con top in maiolica e tutta maiolica, entrambe nelle colorazioni bianco, nero e bordeaux.

A true heating system. The BRERA MAIOLICA hydro stove is designed to heat the entire house and produce domestic hot water. Its high performances, versatility and structural characteristics make it one of a kind. It is available in three versions: the standard one to heat radiators and domestic water; the version with 'basic ventilation' which doesn't only heat radiators and domestic water but also the room where it is installed through hot air; and lastly the version with the 'comfort system' which allows to benefit only of the air heating, ideal for the mid-season periods and for low temperature systems before turning on the central heating system. You can choose between two finishes: steel with ceramic top or full ceramic, both in the colors white, black or bordeaux.



COLORI COLOURS



MAIOLICA BIANCO
WHITE CERAMIC



MAIOLICA BORDEAUX
BORDEAUX CERAMIC



MAIOLICA NERO
BLACK CERAMIC



I-DEA ANGOLO IDRO*



PELLET



ACQUA
WATER

17 kW

Le stufe a pellet I-DEA ANGOLO IDRO dal design innovativo e la ridotta profondità di soli 30 cm aggiungono alla loro bellezza la vista panoramica della fiamma su due lati. I-DEA ANGOLO IDRO è adatta per tutte le abitazioni può riscaldare autonomamente l'intera abitazione tramite termosifoni o altro; è una stufa ermetica ed è fornita completa di kit idraulico già montato e collaudato. Puoi scegliere la cornice esterna in acciaio nelle colorazioni nero bianco e tortora, come pure il pannello frontale, sempre a scelta, tra il gres avorio o ruggine, la pietra ollare sabbziata, il vetro temperato nero rigato, l'acciaio nero.

The I-DEA ANGOLO IDRO pellet stove features an innovative design and a depth of just 30 cm, as well as a panoramic view of the flame on two sides. I-DEA ANGOLO IDRO is suitable for all kinds of rooms, it can heat autonomously the entire house through the radiators or other; it is a hermetic stove and it comes complete with a hydraulic kit already mounted and tested. You can choose the color of the steel frame (black, white or dove-grey) and the finishes of the front panel: ivory, rust, soapstone, tempered striped black glass or black steel.



PROFILO PROFILE COLOUR



BIANCO
WHITE



NERO
BLACK



TORTORA
DOVE GREY

PANNELLO FRONTALE FRONT PANEL



GRES AVORIO
IVORY GRES



ACCIAIO GRIGIO
TORTORA
DOVE GREY
STEEL



ACCIAIO NERO
BLACK STEEL



PIETRA OLLARE
SOAPSTONE



GRES RUGGINE
RUST GRES



VETRO NERO
RIGATO
STRIPED BLACK
GLASS

* Prodotti disponibili fino ad esaurimento scorte
* Until stock last



I-DEA FRONTALE IDRO*



PELLET



ACQUA
WATER

17 kW

Le stufe a pellet I-DEA FRONTALE IDRO dal design innovativo e la ridotta profondità di soli 30 cm sono adatte per tutte le abitazioni e possono riscaldare autonomamente l'intera abitazione tramite termosifoni o altro; I-DEA FRONTALE IDRO è una stufa ermetica ed è fornita completa di kit idraulico già montato e collaudato. Puoi scegliere la cornice esterna in acciaio nelle colorazioni nero bianco e tortora, come pure il pannello frontale, sempre a scelta, tra il gres avorio o ruggine, la pietra ollare sabbata, il vetro temperato nero rigato, l'acciaio nero.

The IDEA FRONTALE IDRO pellet stove features an innovative design and a depth of just 30 cm; they are suitable for all kinds of rooms and they can heat autonomously the entire house through the radiators or other. I-DEA FRONTALE IDRO is a hermetic stove and it comes complete with a hydraulic kit already mounted and tested. You can choose the color of the steel frame (black, white or dove-grey) and the finishes of the front panel: ivory, rust, soapstone, tempered striped black glass or black steel.



PROFILO PROFILE COLOUR



BIANCO
WHITE



NERO
BLACK



TORTORA
DOVE GREY

PANNELLO FRONTALE FRONT PANEL



GRES AVORIO
IVORY GRES



ACCIAIO GRIGIO
TORTORA
DOVE GREY
STEEL



ACCIAIO NERO
BLACK STEEL



PIETRA OLLARE
SOAPSTONE



GRES RUGGINE
RUST GRES



VETRO NERO
RIGATO
STRIPED BLACK
GLASS

* Prodotti disponibili fino ad esaurimento scorte
* Until stock last



I-DEA QUADRA IDRO*



17 kW

Le stufe a pellet I-DEA QUADRA IDRO dal design innovativo e la ridotta profondità di soli 30 cm sono adatte per tutte le abitazioni e possono riscaldare autonomamente l'intera abitazione tramite termosifoni o altro; I-DEA QUADRA IDRO è una stufa ermetica ed è fornita completa di kit idraulico già montato e collaudato. Puoi scegliere la cornice esterna in acciaio nelle colorazioni nero bianco e tortora, come pure il pannello frontale, sempre a scelta, tra la pietra ollare sabbiata, il tortora o l'acciaio nero.

The IDEA QUADRA IDRO pellet stove features an innovative design and a depth of just 30 cm; they are suitable for all kinds of rooms and they can heat autonomously the entire house through the radiators or other. I-DEA QUADRA IDRO is a hermetic stove and it comes complete with a hydraulic kit already mounted and tested. You can choose the color of the steel frame (black, white or dove-grey) and the finishes of the front panel: soapstone or black steel. You can choose the external steel frame in black, white or dove-grey; also, you can choose the front panel in soapstone, dove grey or black steel.



PROFILO PROFILE COLOUR



BIANCO
WHITE



NERO
BLACK



TORTORA
DOVE GREY

PANNELLO FRONTALE FRONT PANEL



ACCIAIO NERO
BLACK STEEL



PIETRA OLLARE
SOAPSTONE



TORTORA
DOVE GREY

* Prodotti disponibili fino ad esaurimento scorte
* Until stock last



SYNTHESIS MODULAR IDRO



21 kW

Il termocamino a pellet che riscalda tutta la casa tramite l'impianto idraulico. SYNTHESIS MODULAR IDRO è progettato per riscaldare in modo autonomo o parallelo medie grandi abitazioni. Le dimensioni compatte, la modularità dei vari accessori lo rendono versatile per rinnovare vecchi caminetti o per la realizzazione di nuove strutture.

Le linee pulite e il design ricercato ed esclusivo del frontale donano una bella visione della fiamma.

Per un maggior comfort e rapidità di riscaldamento, SYNTHESIS MODULAR IDRO dispone di un ventilatore per arieggiare il locale, attivabile e regolabile a piacere. Pratico e facile da utilizzare, tutti i comandi di funzionamento e di regolazione avvengono tramite un radiocomando intuitivo fornito in serie. Anche il kit idraulico è fornito in serie ed è già collaudato. Con il dispositivo wifi è possibile gestire il funzionamento del camino e regolare la temperatura a distanza tramite telefono o tablet.

The pellet fireplace that heats the whole house through the system. SYNTHESIS MODULAR IDRO has been designed to warm in autonomy or in parallel with another heat device a house of middle or big dimensions. The compact size and the organization of the different accessories make this product adaptable for renewing old fireplaces or for the creation of new structures. The refined lines and the elegant and exclusive design of the front give a wonderful view of the flame. For a better comfort and faster warming, SYNTHESIS MODULAR IDRO has a fan in order to air out the room, which can be powered on and it can be regulated, as one prefers. Practical and easy to use, all the functioning and adjusting controls can be set up using the radio remote control, supplied as standard. The hydraulic kit is also already given and already tested. Using the Wi-Fi system control, you can also manage the operation of the fireplace and adjust the temperature with a remote control using the smartphone or tablet.





J20 - J25



PELLET



ACQUA
WATER

20 kW

25 kW

Caldaia a pellet performante ed innovativa, adatta a locale tecnico. Grazie ai suoi 20/25 kW è in grado di riscaldare in modo autonomo l'intera abitazione e produrre acqua calda sanitaria. Le caldaie della serie J20-J25 sono progettate per un maggior comfort di utilizzo. Tutti i modelli sono dotati di sistemi automatici che permettono una lunga autonomia di funzionamento, riducendo le manutenzioni e la pulizia. I diversi motori azionano meccanismi per rimuovere la fuliggine dagli scambiatori, spostando i residui della combustione nel capiente compattatore laterale. Questo processo garantisce una lunga autonomia di funzionamento (circa 1000 kg di pellet bruciato). L'alta efficienza delle caldaie J20-J25 permette di beneficiare di contributi e incentivi legati al risparmio energetico. Le caldaie della serie J20-J25 possono essere integrate ad altre fonti di energia, come pannelli solari e generatori. Come optional, può essere dotata di un contenitore supplementare con capienza di 200 kg. Tutti i comandi possono essere eseguiti tramite la semplice interfaccia del display touch di serie. È possibile aggiungere il dispositivo Wifi e gestire il funzionamento della caldaia a distanza tramite web app, dal proprio smartphone o tablet.

High-performing and innovative pellet boiler, for boiler room. With its 20/25 kW it is able to heat independently the whole house and to produce domestic hot water. J20-J25 boilers are designed for a greater comfort of use. All models are equipped with automatic systems allowing a long operating autonomy, thus reducing cleaning and maintenance operations. Its different motors activate cleaning systems to remove the soot from the exchangers, moving the combustion residues into the large side compactor. This process guarantees a longer operation autonomy (around 1000 kg of burned pellet). J20-J25 boilers can be integrated to other energy sources, such as solar panels or generators. As an optional, there is an additional container with a maximum capacity of 200 kg. All commands are managed through the integrated touch display. It is possible to add a Wi-Fi device to manage the boiler from smartphone or tablet by using the specific App.





J30 - J35



PELLET



ACQUA
WATER

30 kW

35 kW

Caldaia a pellet performante ed innovativa, adatta a locale tecnico. Grazie ai suoi 30/35 kW è in grado di riscaldare in modo autonomo l'intera abitazione e produrre acqua calda sanitaria. Le caldaie della serie J30-J35 sono progettate per un maggior comfort di utilizzo. Tutti i modelli sono dotati di sistemi automatici che permettono una lunga autonomia di funzionamento, riducendo le manutenzioni e la pulizia. I diversi motori azionano meccanismi per rimuovere la fuliggine dagli scambiatori, spostando i residui della combustione nel capiente compattatore laterale. Questo garantisce una lunga autonomia di funzionamento (circa 1000 kg di pellet bruciato).

L'alta efficienza delle caldaie J30-J35 permette di beneficiare di contributi e incentivi legati al risparmio energetico. Le caldaie della serie J30-J35 possono essere integrate ad altre fonti di energia, come pannelli solari e generatori. Come optional, può essere dotata di un contenitore supplementare con capienza di 200 kg. Tutti i comandi possono essere eseguiti tramite la semplice interfaccia del display touch di serie. È possibile aggiungere il dispositivo Wifi e gestire il funzionamento della caldaia a distanza tramite web app, dal proprio smartphone o tablet.

High-performing and innovative pellet boiler, for boiler room. With its 30/35 kW it is able to heat independently the whole house and to produce domestic hot water. J30-J35 boilers are designed for a greater comfort of use. All models are equipped with automatic systems allowing a long operating autonomy, thus reducing cleaning and maintenance operations. Its different motors activate cleaning systems to remove the soot from the exchangers, moving the combustion residues into the large side compactor. This process guarantees a longer operation autonomy (around 1000 kg of burned pellet). J30-J35 boilers can be integrated to other energy sources, such as solar panels or generators. As an optional, there is an additional container with a maximum capacity of 200 kg. All commands are managed through the integrated touch display. It is possible to add a Wi-Fi device to manage the boiler from smartphone or tablet by using the specific App.





CARATTERISTICHE MAIN FEATURES

					
	V-SION	PIXIE	CHRISSIE	CULT	BOTERO 2
<p>USCITA FUMI SUPERIORE E POSTERIORE Per adattarsi alle diverse soluzioni abitative è possibile ordinare l'uscita fumi più adatta; posteriore o superiore. UPPER AND REAR SMOKE OUTLET It is possible to order the most suitable smoke outlet or upper, to suit any kind of building.</p>	✓	✓	✓	✓	✓
<p>INSTALLABILE ANCHE CON CANNA FUMARIA COASSIALE (in fase di ordine) L'installazione con canna fumaria coassiale è ideale per gli edifici passivi, a basso consumo energetico. INSTALLABLE ALSO WITH COAXIAL FLUE (to buy when ordering) The installation with a coaxial flue is ideal for low energy consumption passive buildings.</p>	✓	✓	✓	-	✓
<p>SISTEMA ERMETICO AIRTIGHT SYSTEM</p>	✓	✓	✓	-	✓
<p>COAXIAL CONTROL Il dispositivo regola automaticamente la combustione del pellet migliorando l'efficienza e la sicurezza in base al tipo di installazione. COAXIAL CONTROL The coaxial control device automatically regulates pellet combustion, improving efficiency and safety according to the type of installation.</p>	-	-	✓	-	✓
<p>FLAMME CONTROL Sistema di ottimizzazione della combustione. FLAME CONTROL Device to optimize the pellet combustion.</p>	-	-	-	-	-
<p>CANALIZZABILE DUCTABLE</p>	OPTIONAL	-	OPTIONAL	-	OPTIONAL
<p>UMIDIFICATORE INCORPORATO La presenza di umidificatore incorporato migliora la qualità dell'aria e assicura un ambiente più salutare. Basta aggiungervi poche gocce della vostra essenza preferita per profumare tutta la casa. BUILT-IN HUMIDIFIER The built-in humidifier improves the quality of the air and ensures a healthier environment. Simply add a few drops of scent to diffuse your favourite fragrance throughout your home.</p>	-	-	OPTIONAL	-	✓
<p>SILENT La particolare costruzione e la qualità dei componenti utilizzati permettono alla stufa di funzionare in modo silenzioso. SILENT The particular construction and top quality components used mean the stove runs silently with no noise impact.</p>	✓	✓	✓	✓	✓
<p>CAMERA DI COMBUSTIONE IN FIRELECTOR La camera di combustione, realizzata in Firelector ad alta densità (HD), permette di avere alte temperature tali da ottimizzare il processo di combustione e ridurre le emissioni. FIRELECTOR COMBUSTION CHAMBER The combustion chamber made from high density Firelector provides high temperatures that optimise the combustion process and reduce emissions.</p>	✓	✓	✓	✓	✓
<p>PORTA IN DOPPIO VETRO L'elegante porta in doppio vetro serigrafato caratterizza ulteriormente il design della stufa valorizzando la fiamma interna. DOUBLE GLASS DOOR The elegant screen-printed double glass door characterises the design of the stove enhancing the internal flame.</p>	-	-	✓	✓	✓
<p>RADIOCOMANDO MULTILINGUA La centralina elettronica multilingua touch controlla tutte le funzioni della termosufa direttamente da radiocomando. È possibile tramite un accessorio optional GPRS o wifi gestire l'accensione e lo spegnimento con telefono. MULTI-LANGUAGE REMOTE RADIO CONTROL The multi-language electronic control unit manages all the heating stove functions via a remote radio control device. The optional GSM or Wi-Fi accessory can also be used to turn the system on and off via smart phone.</p>	✓	✓	✓	✓	✓
<p>TELECOMANDO TOUCH IR Telecomando intuitivo che ti permette di impostare il calore in casa in modo semplice e veloce. IR TOUCH REMOTE CONTROL User-friendly remote control used to quickly and easily set the temperature in the home.</p>	-	-	-	-	-
<p>VALVOLA DI SICUREZZA Valvola di sicurezza per lo sfogo della pressione dei gas in eccesso. SAFETY VALVE Safety valve used to escape excessive gas pressure.</p>	✓	✓	✓	✓	✓
<p>SUPER FINE Una profondità di soli 27 cm stufe ad aria, 30 cm stufe ad acqua. SUPER SLIM A depth of only 27 cm air stoves, 30 cm heating stoves.</p>	-	-	-	-	-
<p>DISPOSITIVO WIFI Il dispositivo wi-fi ti permette di comunicare con la tua stufa gestendone il funzionamento anche fuori casa. WI-FI DEVICE The Wi-Fi device allows you to communicate with your stove and manages its function even when you are away from home.</p>	✓	✓	✓	✓	✓





PELLET

								
	ODETTE	MELTEMI	I-DEA 2 ANGOLO	I-DEA 2 FRONTALE	AMBRIA 2	PADDY	SYNTHESIS 60	SYNTHESIS MODULAR
	✓	✓	✓	✓	-	✓	-	-
	✓	✓	✓	✓	-	-	✓	-
	✓	✓	✓	✓	-	-	✓	-
	✓	✓	✓	✓	-	-	-	-
	-	-	-	-	-	-	-	-
	OPTIONAL	OPTIONAL	OPTIONAL	OPTIONAL	-	OPTIONAL	-	OPTIONAL
	OPTIONAL	-	✓	✓	-	-	-	-
	✓	✓	✓	✓	✓	✓	✓	✓
	✓	✓	✓	✓	✓	✓	✓	✓
	✓ per mod. 8 kW, 10 kW	✓	-	-	-	-	-	-
	✓	✓	✓	✓	✓	✓	✓	✓
	-	-	-	-	-	-	-	-
	✓	✓	✓	✓	✓	✓	✓	✓
	-	-	✓	✓	-	-	-	-
	✓	✓	✓	✓	OPTIONAL	OPTIONAL	✓	✓

CARATTERISTICHE MAIN FEATURES

<p>USCITA FUMI SUPERIORE E POSTERIORE Per adattarsi alle diverse soluzioni abitative è possibile utilizzare l'uscita fumi più adatta; posteriore o superiore. UPPER AND REAR SMOKE OUTLET It is possible to use the most suitable smoke outlet or upper, to suit any kind of building.</p>	-	-	-
<p>INSTALLABILE ANCHE CON CANNA FUMARIA COASSIALE L'installazione con canna fumaria coassiale è ideale per gli edifici passivi, a basso consumo energetico. INSTALLABLE ALSO WITH COAXIAL FLUE The installation with a coaxial flue is ideal for low energy consumption passive buildings.</p>	-	-	-
<p>SISTEMA ERMETICO AIRTIGHT SYSTEM</p>	-	-	-
<p>COAXIAL CONTROL Il dispositivo regola automaticamente la combustione del pellet migliorando l'efficienza e la sicurezza in base al tipo di installazione. COAXIAL CONTROL The coaxial control device automatically regulates pellet combustion, improving efficiency and safety according to the type of installation.</p>	-	✓	✓
<p>FLAMME CONTROL Sistema di ottimizzazione della combustione. FLAME CONTROL Device to optimize the pellet combustion.</p>	-	-	-
<p>CANALIZZABILE DUCTABLE</p>	-	-	-
<p>UMIDIFICATORE INCORPORATO La presenza di umidificatore incorporato migliora la qualità dell'aria e assicura un ambiente più salutare. Basta aggiungervi poche gocce della vostra essenza preferita per profumare tutta la casa. BUILT-IN HUMIDIFIER The built-in humidifier improves the quality of the air and ensures a healthier environment. Simply add a few drops of scent to diffuse your favourite fragrance throughout your home.</p>	-	-	-
<p>SILENT La particolare costruzione e la qualità dei componenti utilizzati permettono alla stufa di funzionare in modo silenzioso. SILENT The particular construction and top quality components used mean the stove runs silently with no noise impact.</p>	-	-	-
<p>CAMERA DI COMBUSTIONE IN FIRELECTOR La camera di combustione, realizzata in Firelector ad alta densità (HD), permette di avere alte temperature tali da ottimizzare il processo di combustione e ridurre le emissioni. FIRELECTOR COMBUSTION CHAMBER The combustion chamber made from high density Firelector provides high temperatures that optimise the combustion process and reduce emissions.</p>	-	-	-
<p>PORTA IN DOPPIO VETRO L'elegante porta in doppio vetro serigrafato caratterizza ulteriormente il design della stufa valorizzando la fiamma interna. DOUBLE GLASS DOOR The elegant screen-printed double glass door characterises the design of the stove enhancing the internal flame.</p>	✓	-	-
<p>RADIOCOMANDO O DISPLAY MULTILINGUA La centralina elettronica multilingua touch controlla tutte le funzioni della termostufa direttamente da radiocomando. È possibile tramite un accessorio optional GPRS o wifi gestire l'accensione e lo spegnimento con telefono. MULTI-LANGUAGE REMOTE RADIO CONTROL OR DISPLAY The multi-language electronic control unit manages all the heating stove functions via a remote radio control device. The optional GSM or Wi-Fi accessory can also be used to turn the system on and off via smart phone.</p>	✓	✓	✓
<p>TELECOMANDO TOUCH IR Telecomando intuitivo che ti permette di impostare il calore in casa in modo semplice e veloce. IR TOUCH REMOTE CONTROL User-friendly remote control used to quickly and easily set the temperature in the home.</p>	-	-	-
<p>VALVOLA DI SICUREZZA Valvola di sicurezza per lo sfogo della pressione dei gas in eccesso. SAFETY VALVE Safety valve used to escape excessive gas pressure.</p>	✓	✓	✓
<p>SUPER FINE Una profondità di soli 27 cm SUPER SLIM A depth of only 27 cm</p>	-	-	-
<p>DISPOSITIVO WIFI Il dispositivo wi-fi ti permette di comunicare con la tua stufa gestendone il funzionamento anche fuori casa. WI-FI DEVICE The Wi-Fi device allows you to communicate with your stove and manages its function even when you are away from home.</p>	✓	✓	✓
<p>KIT IDRAULICO Montato e testato in fabbrica. PLUMBING KIT Already assembled and tested.</p>	✓	✓	✓

			
	DUKA	BRERA ACCIAIO	BRERA MAIOLICA
	-	-	-
	-	-	-
	-	-	-
	-	✓	✓
	-	-	-
	-	-	-
	-	-	-
	✓	-	-
	✓	✓	✓
	-	-	-
	✓	✓	✓
	-	-	-
	✓	✓	✓
	✓	✓	✓



ACQUA - WATER

PELLET



I-DEA ANGOLO IDRO



I-DEA FRONTALE IDRO



I-DEA QUADRA IDRO



SYNTHESIS MODULAR IDRO

























J20 - J25



J30 - J35

✓	✓	✓	-	✓	✓
-	-	-	-	-	-
-	-	-	-	-	-
-	-	-	-	-	-
✓	✓	✓	-	-	-
-	-	-	-	-	-
-	-	-	-	-	-
-	-	-	-	-	-
-	-	-	-	-	-
✓	✓	✓	✓	-	-
✓	✓	✓	-	-	-
-	-	-	✓	-	-
✓	✓	✓	-	-	-
-	-	-	✓	OPTIONAL	OPTIONAL
✓	✓	✓	✓	✓	✓

DATI TECNICI MAIN FEATURES

	 V-SION 8 kW	 PIXIE 7 kW	 CHRISSIE 6 kW	 CULT 8 kW
POTENZA BRUCIATA* BURNED POWER* kW	9,2	7,7	6,7	9
POTENZA NOMINALE THERMAL RATED OUTPUT kW	8,4	6,8	6,3	8,2
POTENZA MINIMA MINIMAL OUTPUT kW	4,2	3,4	2,9	2,9
POTENZA RESA AL FLUIDO POWER GIVEN TO FLUID kW	-	-	-	-
RENDIMENTO EFFICIENCY (min-max)%	93,9-90,7	91,6-88,3	95,1-93,5	95,1-91,1
Ø ASPIRAZIONE ARIA COMBURENTE COMBUSTION AIR INTAKE Ø mm	50	50	50	50
Ø USCITA FUMI SMOKE EXHAUST Ø mm	80	80	80	80
CONSUMO CONSUMPTION (min - max) kg/h	0,94-1,93	0,78-1,62	0,62-1,39	0,62-1,88
CAPACITÀ SERBATOIO PELLETT TANK CAPACITY kg	15	13	18	15
TEMPERATURA FUMI FLUE-GAS TEMPERATURE °C	164,6	172,7	112,4	144,6
TIRAGGIO MINIMO MINIMUM DRAFT Pa	10	10	10	10
CO (13% O ₂)* mg/m ³	157	187	81	137
MASSA FUMI* FLUE-GAS MASS FLOW* g/s	4,9	5	4,45	5,98
POLVERI - DUSTS (13% O ₂)* mg/m ³	15	10	17	14
NOX (13% O ₂)* mg/m ³	135	99	146	145
OGC (13% O ₂)* mg/m ³	3	10	3	0,3
RENDIMENTO ENERGETICO STAGIONALE SEASONAL ENERGY EFFICIENCY	80	85	82	80
PESO - WEIGHT kg	110	135	111,5-124	101,5
GARANZIA CORPO CALDAIA*** anni WARRANTY ON BOILER BODY*** years	2(5)	2(5)	2(5)	2(5)
CLASSE ENERGETICA** ENERGY LABEL**	A+	A+	A+	A+
CERTIFICAZIONI ITALIA - ITALIAN CERTIFICATION DM n° 186, 07/11/17 Conto Termico	4 STELLE  	 	4 STELLE  	4 STELLE  
ALTRE CERTIFICAZIONI OTHER CERTIFICATIONS	EN14785 DTA   	EN14785 DTA   	EN14785 DTA   	EN14785   

* Valori riferiti per potenza nominale (max)

** Secondo una scala da G ad A++

*** Per maggiori informazioni consultare il Libretto di Garanzia

* Power rating (max) values

** With a range from G to A++

*** For further details please refer to the Warranty Booklet



PELLET



BOTERO 2

8 kW

10 kW

9

11

8,2

10

2,9

2,9

-

-

95,1-91,1

95,1-91,2

50

50

80

80

0,62-1,88

0,62-2,27

18

18

144,6

166,5

10

10

137

165

5,98

5,97

14

11

145

131

0,3

2

80

80

115,5-135

115,5-135

2(5)

2(5)

A+

A+

4 STELLE



EN14785

DTA

ECO DESIGN 2022



CE



ODETTE

6 kW

8 kW

10 kW

6,7

9

11

6,3

8,2

10

2,9

2,9

2,9

-

-

-

95,1-93,5

95,1-91,1

95,1-91,2

50

50

50

80

80

80

0,62-1,39

0,62-1,88

0,62-2,27

15

18

18

112,4

144,6

166,5

10

10

10

81

137

165

4,45

5,98

5,97

17

14

11

146

145

131

3

0,3

2

82

80

80

109-131,5

115-137

115-137

2(5)

2(5)

2(5)

A+

A+

A+

4 STELLE



EN14785







DTA

ECO DESIGN 2022



CE

DATI TECNICI MAIN FEATURES

	 MELTEMI		 I-DEA 2 ANGOLO		 I-DEA 2 FRONTALE		 AMBRIA 2	
	12 kW	14 kW	10 kW	10 kW	6 kW	8 kW	10 kW	
POTENZA BRUCIATA* BURNED POWER* kW	13,3	15,8	10,4	10,4	6,9	9	11	
POTENZA NOMINALE THERMAL RATED OUTPUT kW	12	14	9,3	9,3	6,4	8,2	10	
POTENZA MINIMA MINIMAL OUTPUT kW	4,9	4,9	3,2	3,2	2,4	2,4	2,9	
POTENZA RESA AL FLUIDO POWER GIVEN TO FLUID kW	-	-	-	-	-	-	-	
RENDIMENTO EFFICIENCY (min-max)%	93,5-90,7	93,5-88,4	92,0-90,3	92,0-90,3	92,8-92,0	92,8-90,6	95,1- 91,2	
Ø ASPIRAZIONE ARIA COMBURENTE COMBUSTION AIR INTAKE Ø mm	50	50	50	50	50	50	50	
Ø USCITA FUMI SMOKE EXHAUST Ø mm	80	80	80	80	80	80	80	
CONSUMO CONSUMPTION (min - max) kg/h	1,07-2,70	1,07-3,30	0,72-2,15	0,72-2,15	0,53-1,43	0,53-1,87	0,62-2,27	
CAPACITÀ SERBATOIO PELLETT TANK CAPACITY kg	25	25	21	21	15	15	18	
TEMPERATURA FUMI FLUE-GAS TEMPERATURE °C	169,2	218,8	175,5	175,5	134,7	167,8	166,5	
TIRAGGIO MINIMO MINIMUM DRAFT Pa	8	8	10	10	10	10	10	
CO (13% O ₂)* mg/m ³	94	125	181	181	61	113	165	
MASSA FUMI* FLUE-GAS MASS FLOW* g/s	7,53	8,37	5,94	5,94	4,40	5,20	5,97	
POLVERI - DUSTS (13% O ₂)* mg/m ³	19	15	17	17	20	20	11	
NOX (13% O ₂)* mg/m ³	141	115	137	137	158	139	131	
OGC (13% O ₂)* mg/m ³	1	2	2	2	2	3	2	
RENDIMENTO ENERGETICO STAGIONALE SEASONAL ENERGY EFFICIENCY	87	85	81	81	81	80	80	
PESO - WEIGHT kg	224	224	161	159	110	110	115	
GARANZIA CORPO CALDAIA*** anni WARRANTY ON BOILER BODY*** years	2(5)	2(5)	2(5)	2(5)	2(5)	2(5)	2(5)	
CLASSE ENERGETICA** ENERGY LABEL**	A+	A+	A+	A+	A+	A+	A+	
CERTIFICAZIONI ITALIA - ITALIAN CERTIFICATION DM n° 186, 07/11/17 Conto Termico	 		 		 		 	
ALTRE CERTIFICAZIONI OTHER CERTIFICATIONS	   		   		   		   	

* Valori riferiti per potenza nominale (max)

** Secondo una scala da G ad A++

*** Per maggiori informazioni consultare il Libretto di Garanzia

* Power rating (max) values

** With a range from G to A++

*** For further details please refer to the Warranty Booklet



PELLET



PADDY



SYNTHESIS 60



SYNTHESIS MODULAR

	6 kW	8 kW	10 kW	7 kW	9 kW	11,5 kW
	6,9	9	11	7,7	9,8	13
	6,4	8,2	10	6,8	9	11,5
	2,4	2,4	2,9	3,4	4,3	4,3
	-	-	-	-	-	-
	92,8-90,6	92,8-90,6	95,1-91,2	91,6-88,3	93,4-91,6	91,9-88,7
	50	50	50	50	50	50
	80,78-1,62	80	80	80	80	80
	0,53-1,43	0,53-1,87	0,62-2,27	0,78-1,62	0,97-2,07	0,97-2,67
	15	15	18	15	12,5	13,5
	134,7	167,8	166,5	172,7	133,2	190,5
	10	10	10	10	8	10
	61	113	165	187	187	88
	4,40	5,20	5,97	5	6	7,2
	20	20	11	10	11	11
	158	139	131	99	96	114
	2	3	2	10	7	2
	81	80	80	85	88	85
	105	105	110	95	121	133
	2(5)	2(5)	2(5)	2(5)	2(5)	2(5)
	A+	A+	A+	A+	A+	A+

4 STELLE



4 STELLE



EN14785



EN14785







EN14785



CE



DATI TECNICI MAIN FEATURES

	DUKA		BRERA ACCIAIO BRERA MAIOLICA		
	16 kW	19 kW	20 kW	24 kW	28 kW
POTENZA BRUCIATA* BURNED POWER* kW	17,4	20,5	21,9	25,8	30,2
POTENZA NOMINALE THERMAL RATED OUTPUT kW	16,2	19	20,5	24	28
POTENZA MINIMA MINIMAL OUTPUT kW	6,1	6,1	8,8	8,8	8,8
POTENZA RESA AL FLUIDO POWER GIVEN TO FLUID kW	14,8	17,1	17,5	20,4	23,8
RENDIMENTO EFFICIENCY (min-max)%	94,2-93,7	94,2-92,6	93,6-93,4	93,6-93,2	93,6-92,9
Ø ASPIRAZIONE ARIA COMBURENTE COMBUSTION AIR INTAKE Ø mm	50	50	60	60	60
Ø USCITA FUMI SMOKE EXHAUST Ø mm	100	100	100	100	100
CONSUMO CONSUMPTION (min - max) kg/h	1,34-3,62	1,34-4,28	1,93-4,49	1,93-5,28	1,93-6,18
CAPACITÀ SERBATOIO PELLETT TANK CAPACITY kg	30	30	40	40	40
TEMPERATURA FUMI FLUE-GAS TEMPERATURE °C	118	135,9	127,3	136,2	146,5
TIRAGGIO MINIMO MINIMUM DRAFT Pa	8	8	10	10	10
CO (13% O ₂)* mg/m ³	171	156	61	80	102
MASSA FUMI* FLUE-GAS MASS FLOW* g/s	10,02	11,72	12,2	13,5	14,9
POLVERI - DUSTS (13% O ₂)* mg/m ³	20	14	16	15	13
NOX (13% O ₂)* mg/m ³	98	95	132	134	137
OGC (13% O ₂)* mg/m ³	3	3	6	9	12
RENDIMENTO ENERGETICO STAGIONALE SEASONAL ENERGY EFFICIENCY	83	82	91	91	91
PESO - WEIGHT kg	239	239	228-270	228-270	228-270
GARANZIA CORPO CALDAIA*** anni WARRANTY ON BOILER BODY*** years	2(5)	2(5)	2(5)	2(5)	2(5)
CLASSE ENERGETICA** ENERGY LABEL**	A+	A+	A++	A++	A++
CERTIFICAZIONI ITALIA - ITALIAN CERTIFICATION DM n° 186, 07/11/17 Conto Termico	4 STELLE 		4 STELLE 		
ALTRE CERTIFICAZIONI OTHER CERTIFICATIONS	EN14785 		EN14785 		

* Valori riferiti per potenza nominale (max)





















** Secondo una scala da G ad A++

*** Per maggiori informazioni consultare il Libretto di Garanzia

* Power rating (max) values

** With a range from G to A++

*** For further details please refer to the Warranty Booklet

 I-DEA ANGOLO IDRO 17 kW	 I-DEA FRONTALE IDRO 17 kW	 I-DEA QUADRA IDRO 17 kW	 SYNTHESIS MODULAR IDRO 21 kW	 J20 - J25 20 kW 25 kW		 J30 - J35 30 kW 35 kW		
18,3	18,3	18,3	22,9	20	24,3	29,9	34,1	
17	17	17	21,2	18,8	22,8	27,6	31,4	
5	5	5	8,9	5,3	5,9	7,5	7,5	
14,5	14,5	14,5	18,2	18,8	22,8	27,6	31,4	
94,5-93,0	94,5-93,0	94,5-93,0	93,5-92,4	88-94	91-93,7	88,1-92,4	88,1-92,1	
60	60	60	50	50	50	60	60	
80	80	80	100	100	100	100	100	
1,0-3,8	1,0-3,8	1,0-3,8	1,99-4,78	1,26-4,16	1,35-5,07	1,77-6,23	1,77-7,1	
27	27	27	35	100	100	100	100	
126	126	126	142,3	93,6	86,8	99,2	106,4	
11	11	11	8	3-8	3-8	3-10	3-10	
130	130	130	166	17	13	13	20	
10,7	10,7	10,7	12,97	11	13,2	17	19,2	
11	11	11	15	4	6	5	9	
125	125	125	87	114	110	107	118	
8	8	8	1	2	3	2	2	
82	82	82	82	79	81	79	79	
165	165	165	215	310	310	350	350	
2(5)	2(5)	2(5)	2(5)	2(5)	2(5)	2(5)	2(5)	
A+	A+	A+	A+	A+	A+	A+	A+	
4 STELLE 			 		 		 	
EN14785  			EN14785  		EN 303-5  		EN 303-5  	

V-SION

8 kW



PIXIE

7 kW

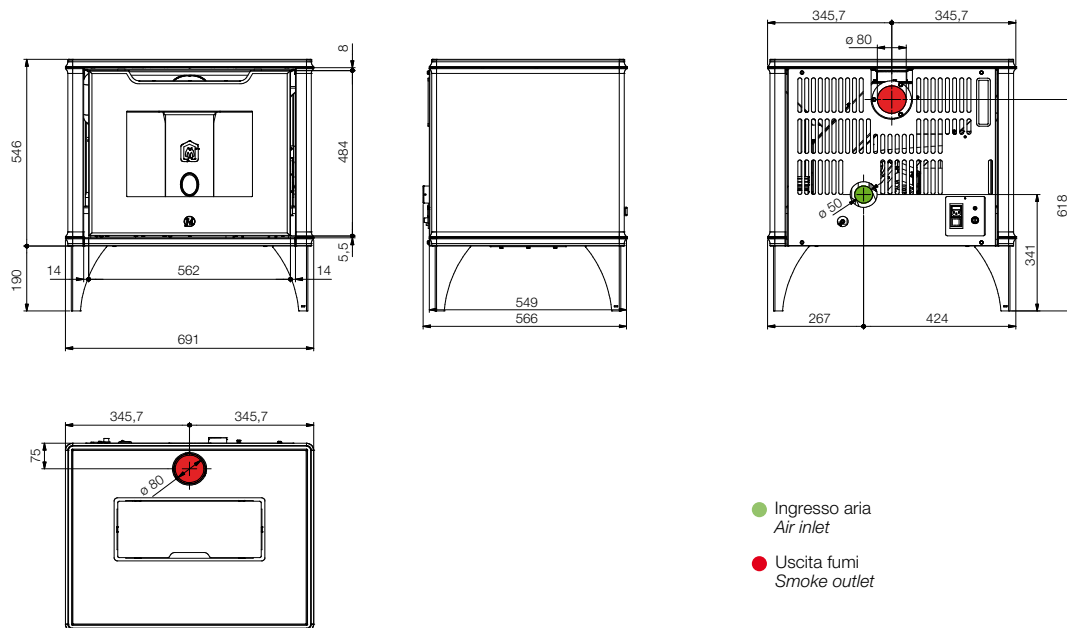

CHRISSIE

6 kW

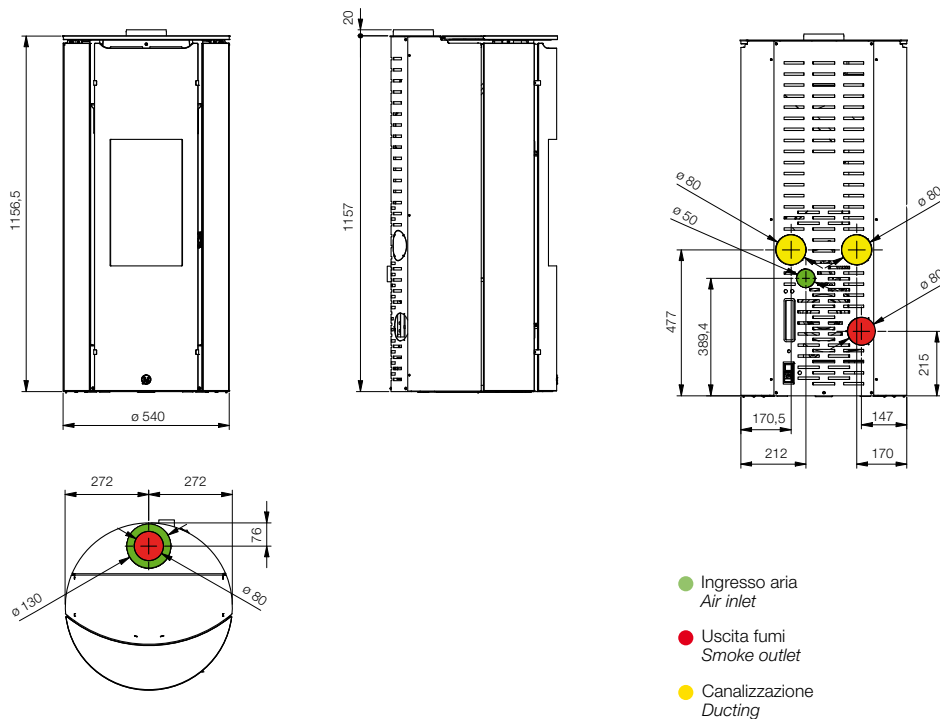

CULT

8 kW

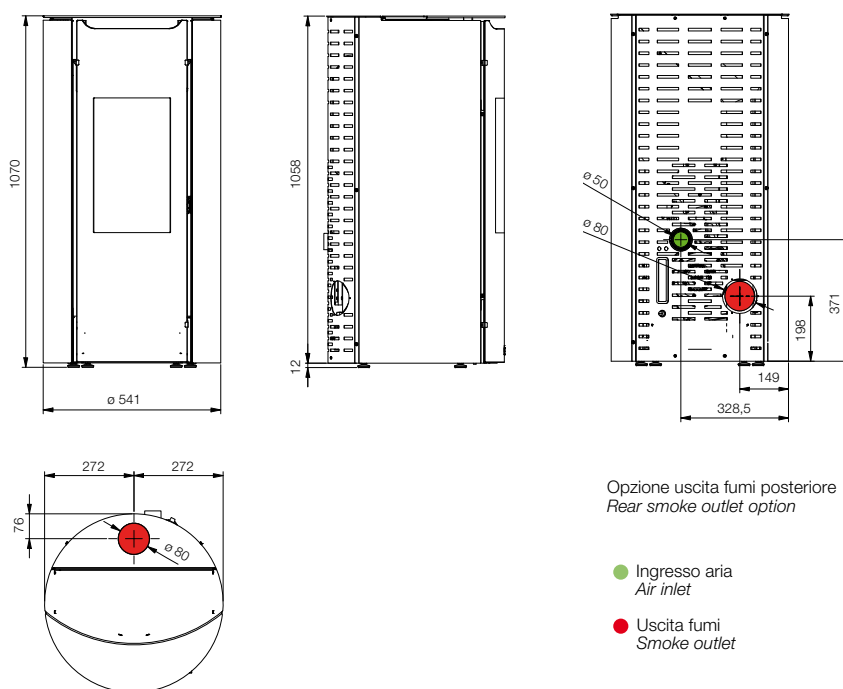

BOTERO 2

8 kW

10 kW

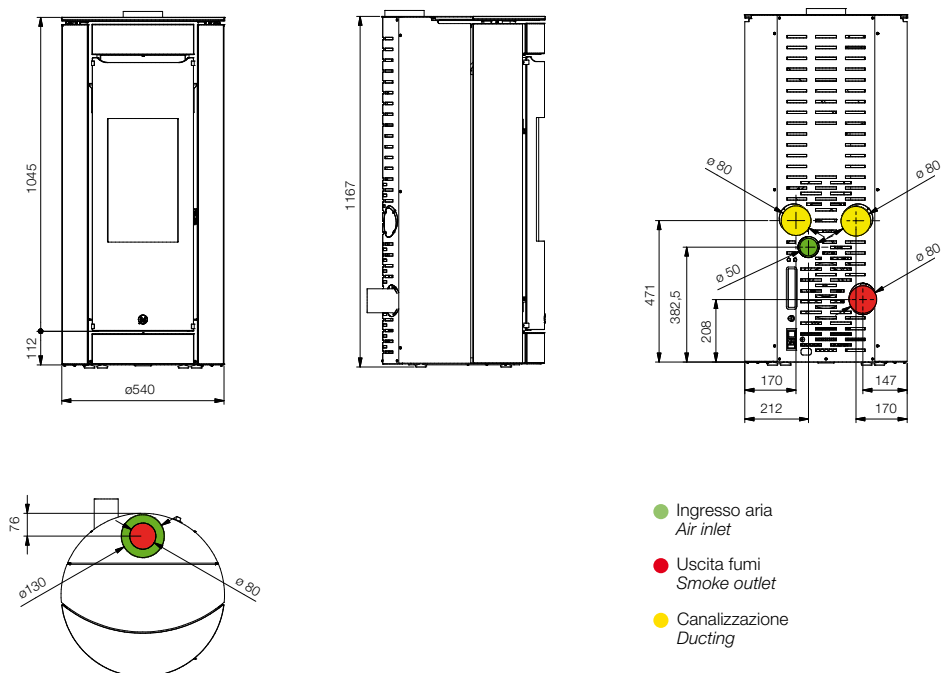

ODETTE

6 kW

6 kW

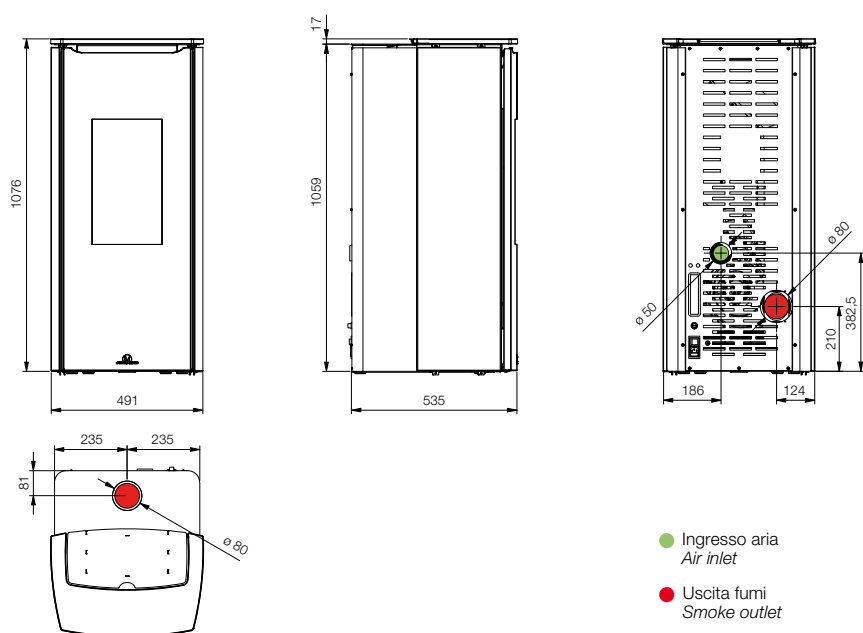

ODETTE

8-10 kW

8 kW

10 kW

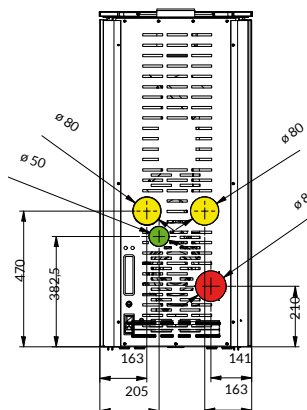
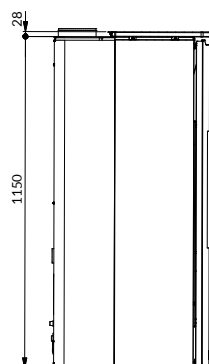
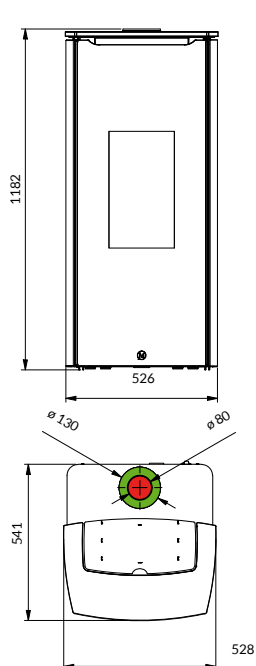

- Ingresso aria
Air inlet
- Uscita fumi
Smoke outlet
- Canalizzazione
Ducting

MELTEMI

12 kW

14 kW

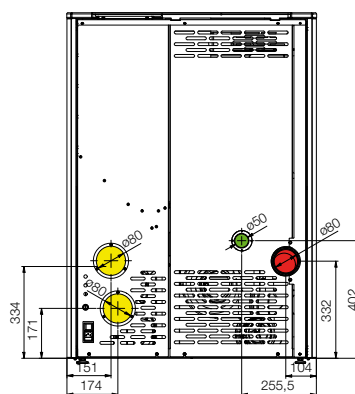
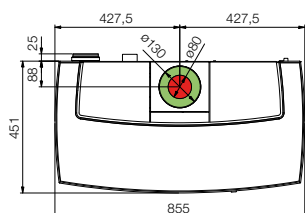
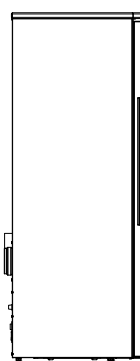
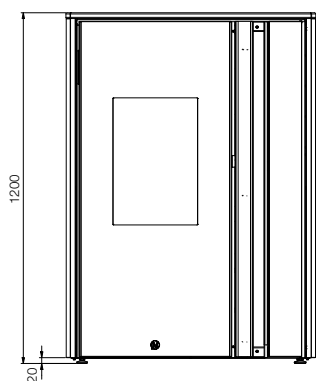

- Ingresso aria
Air inlet
- Uscita fumi
Smoke outlet
- Canalizzazione
Ducting

I-DEA 2

ANGOLO

10 kW

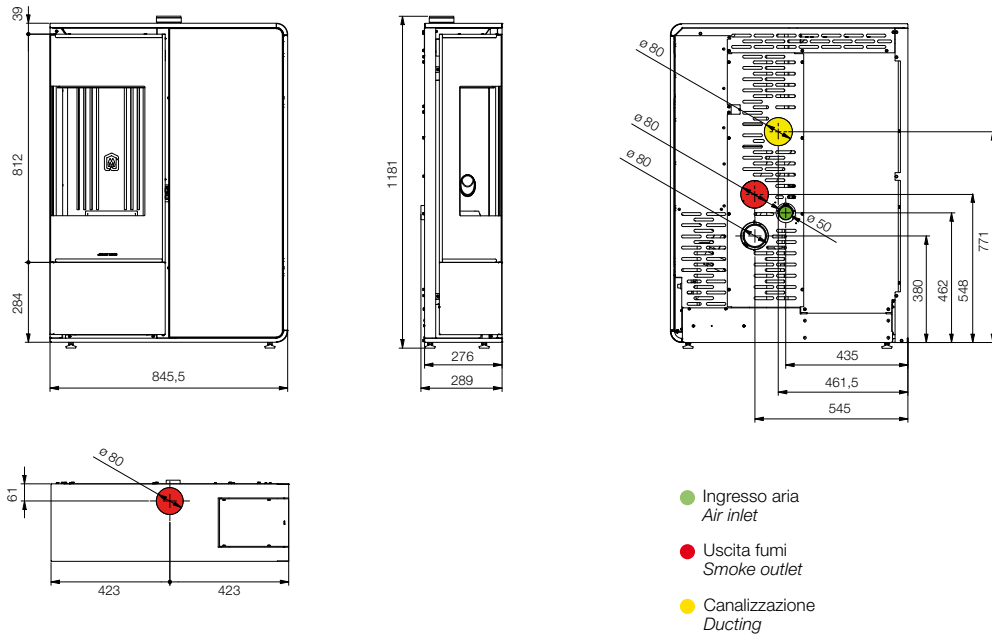

I-DEA 2

FRONTALE

10 kW

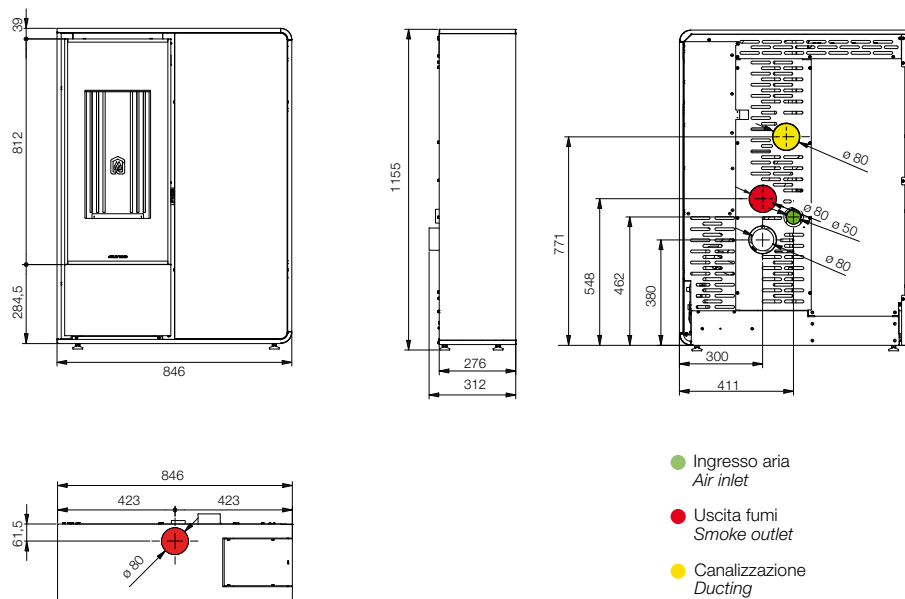

I-DEA 2

ANGOLO

10 kW

USCITA FUMI COASSIALE INTEGRATA
INTEGRATED COAXIAL SMOKE OUTLET

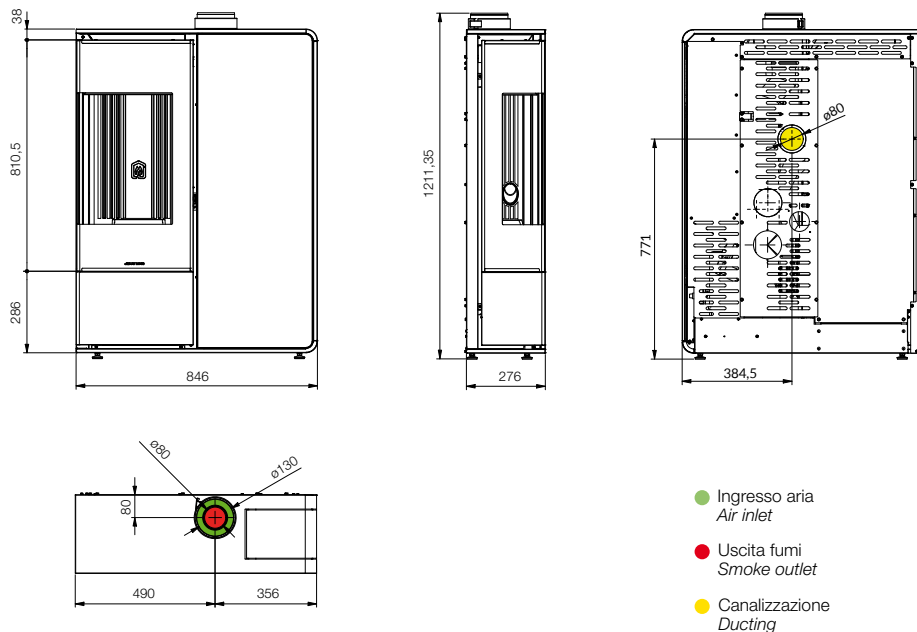

I-DEA 2

FRONTALE

10 kW

USCITA FUMI COASSIALE INTEGRATA
INTEGRATED COAXIAL SMOKE OUTLET

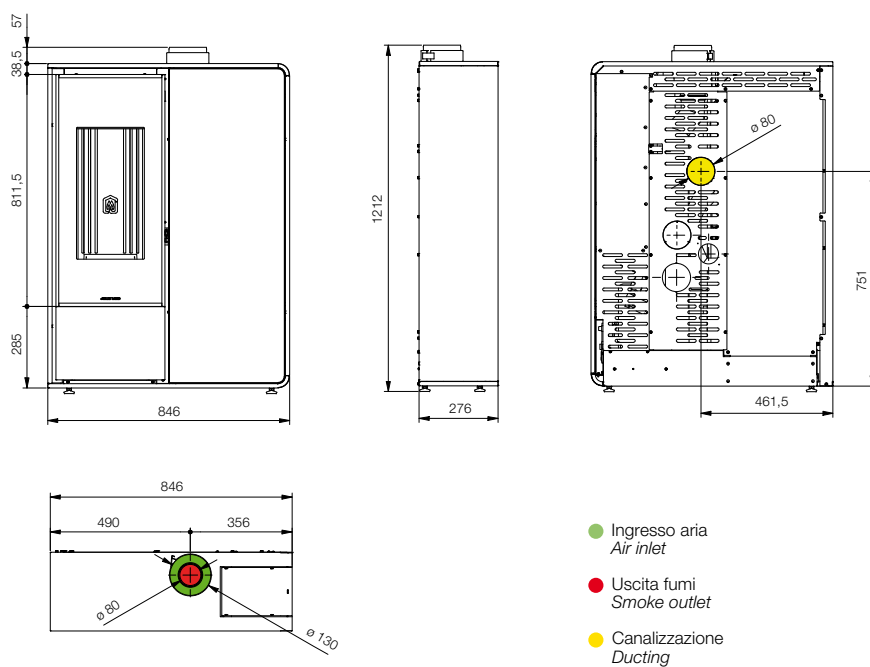

AMBRIA 2

6 kW

8 kW

10 kW

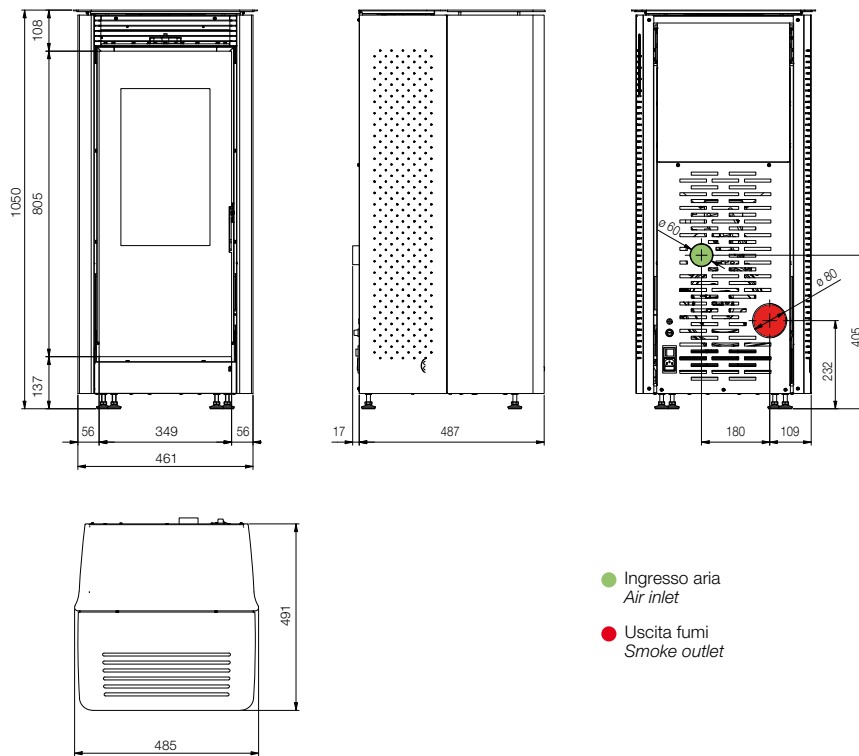

PADDY

6 kW

8 kW

10 kW

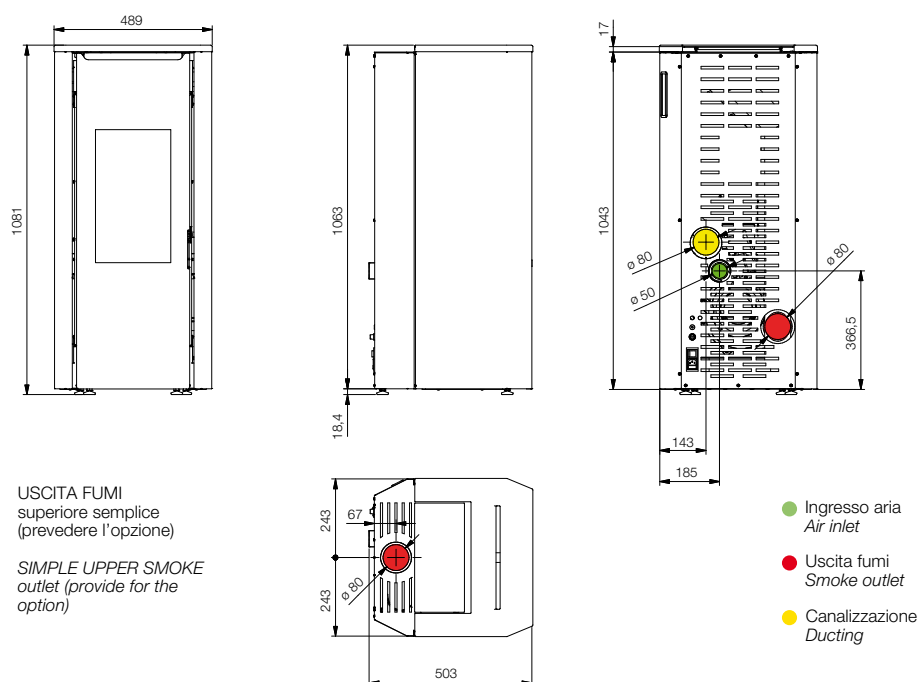

SYNTHESIS 60

INSERTO
INSERT

7 kW

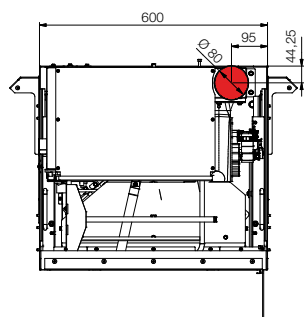
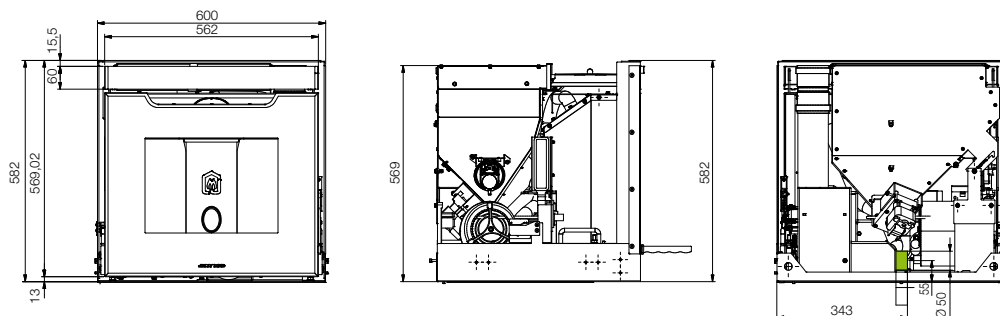

- Ingresso aria
Air inlet
- Uscita fumi
Smoke outlet

SYNTHESIS 60

CAMINETTO
FIREPLACE

7 kW

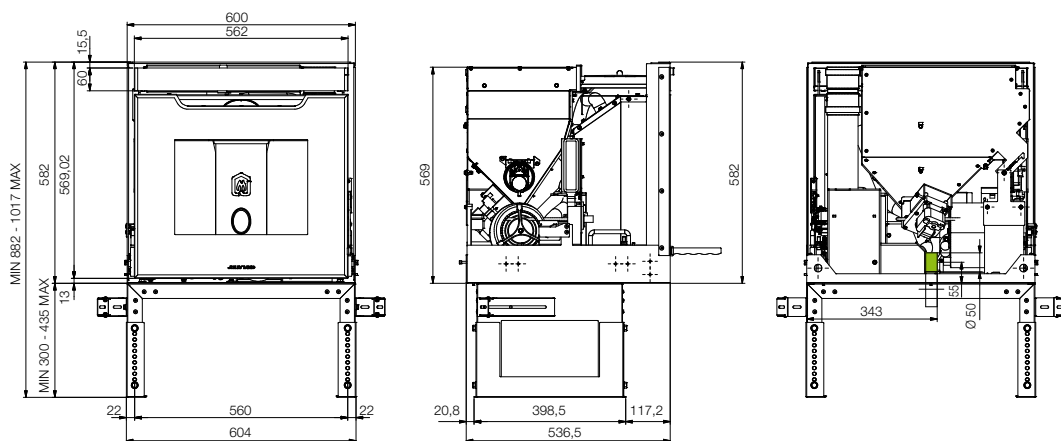

- Ingresso aria
Air inlet
- Uscita fumi
Smoke outlet

SYNTHESIS MODULAR

9 kW

SYNTHESIS MODULAR 68

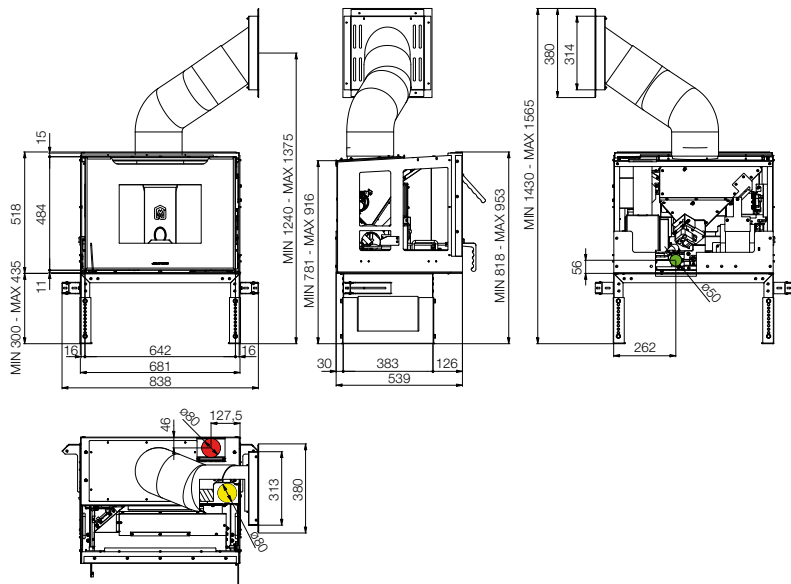

INSERTO + CASSETTO DI CARICAMENTO PELLET INSERT + PELLET LOADING DRAWER

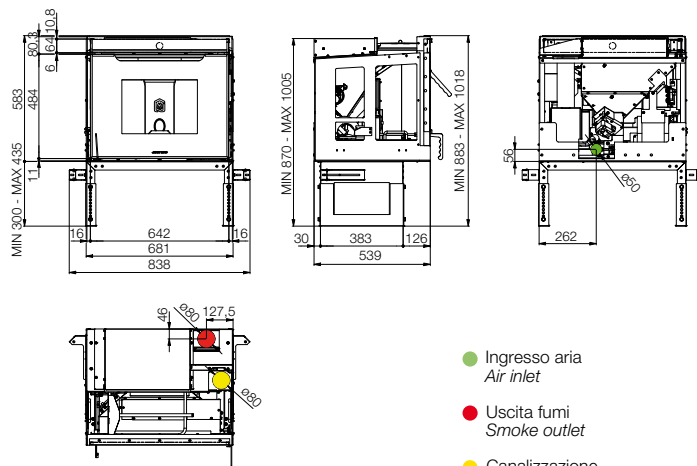

SYNTHESIS MODULAR

9 kW

SYNTHESIS MODULAR 68

INSERTO + RISERVA SUPPLEMENTARE
PELLET + TUBO ORIENTABILE DI
CARICAMENTO PELLET CON SPORTELLO +
CAVALLETTO

INSERT + ADDITIONAL PELLET
TANK + ADJUSTABLE PELLET LOADING
TUBE WITH DOOR + STAND

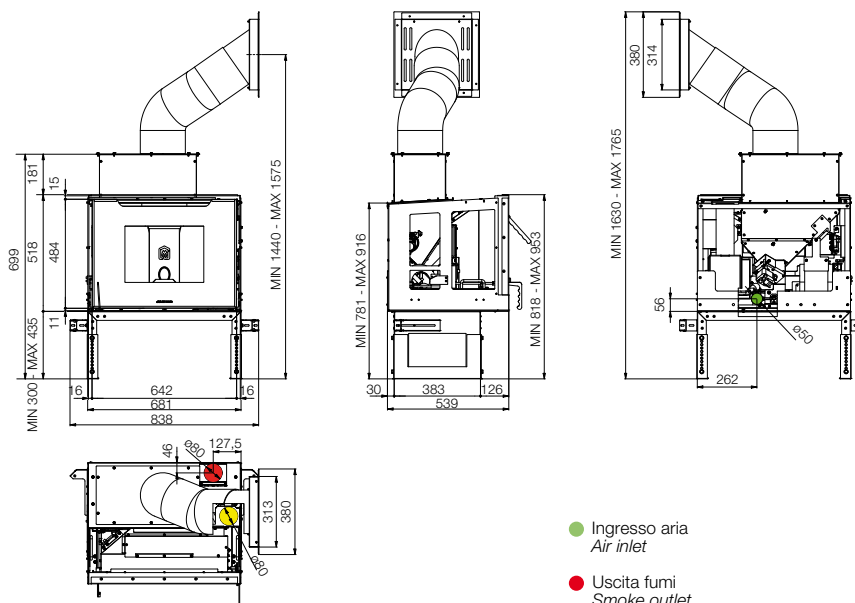

SYNTHESIS MODULAR

11,5 kW

SYNTHESIS MODULAR 80

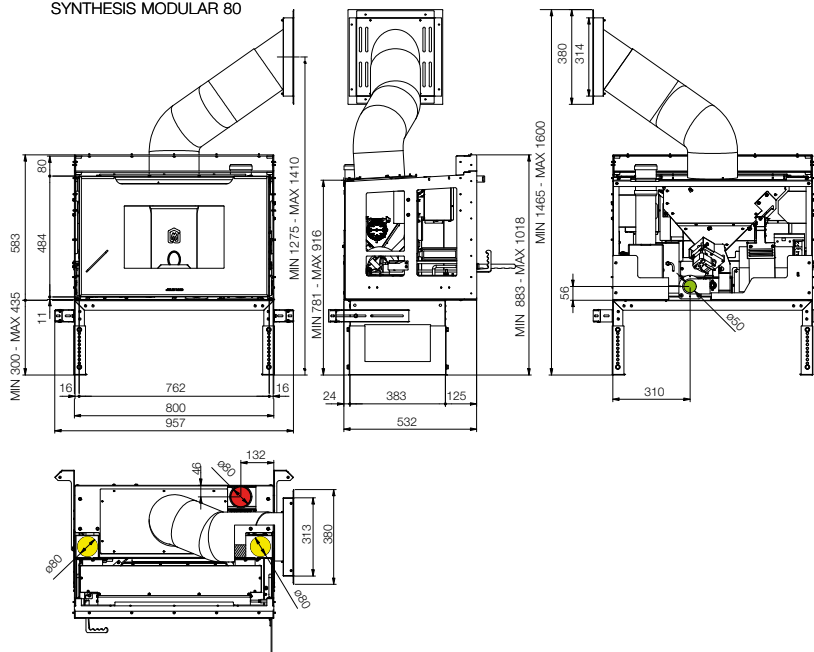

INSERTO + CASSETTO DI CARICAMENTO PELLET INSERT + PELLET LOADING DRAWER

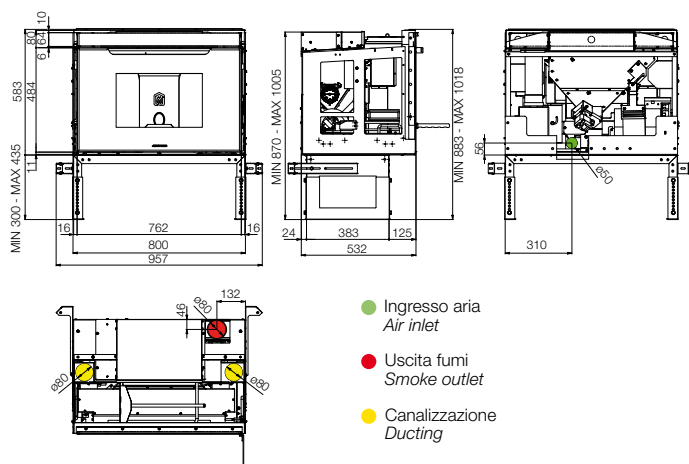

- Ingresso aria
Air inlet
- Uscita fumi
Smoke outlet
- Canalizzazione
Ducting

SYNTHESIS MODULAR

11,5 kW

SYNTHESIS MODULAR 80

INSERTO + RISERVA SUPPLEMENTARE
PELLET + TUBO ORIENTABILE DI
CARICAMENTO PELLET CON SPORTELLO +
CAVALLETTO

INSERT + ADDITIONAL PELLET
TANK + ADJUSTABLE PELLET LOADING TUBE
WITH DOOR + STAND

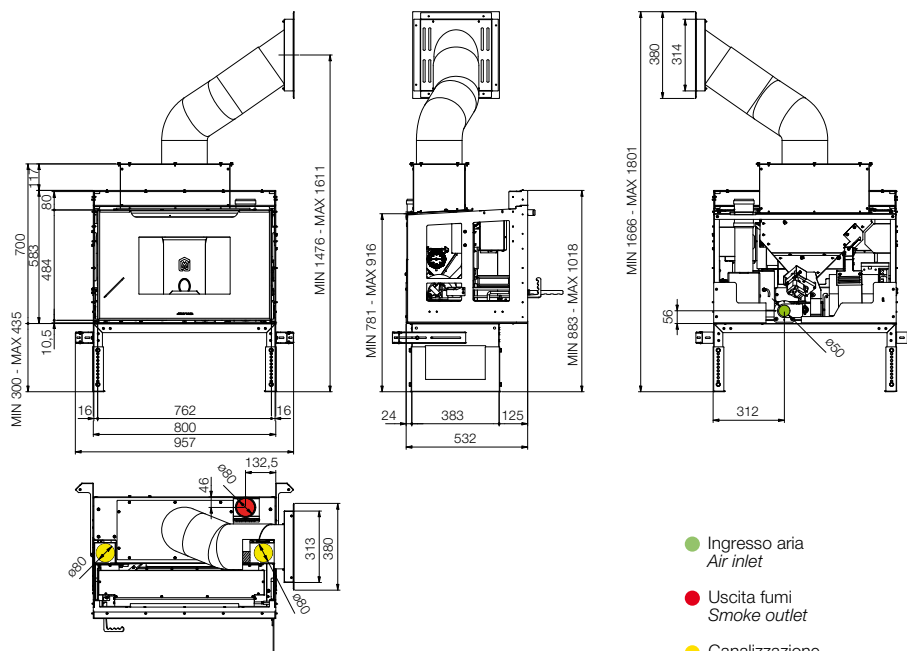

- Ingresso aria
Air inlet
- Uscita fumi
Smoke outlet
- Canalizzazione
Ducting

DUKA

16 kW

19 kW

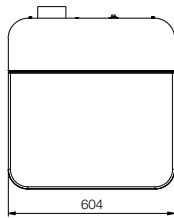
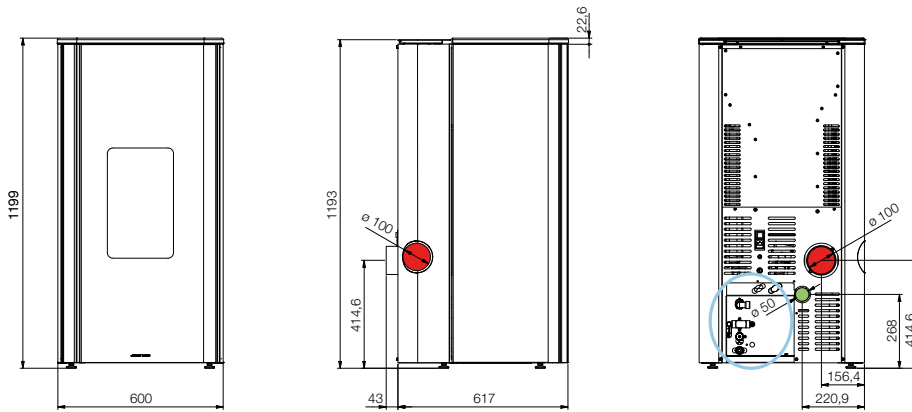

- Ingresso aria
Air inlet
- Uscita fumi
Smoke outlet
- Kit idraulico
3/4" per 16 kW
3/4" per 19 kW
Plumbing kit
3/4" for 16 kW
3/4" for 19 kW

BRERA ACCIAIO

20 kW

24 kW

28 kW

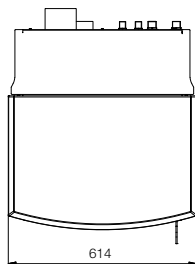
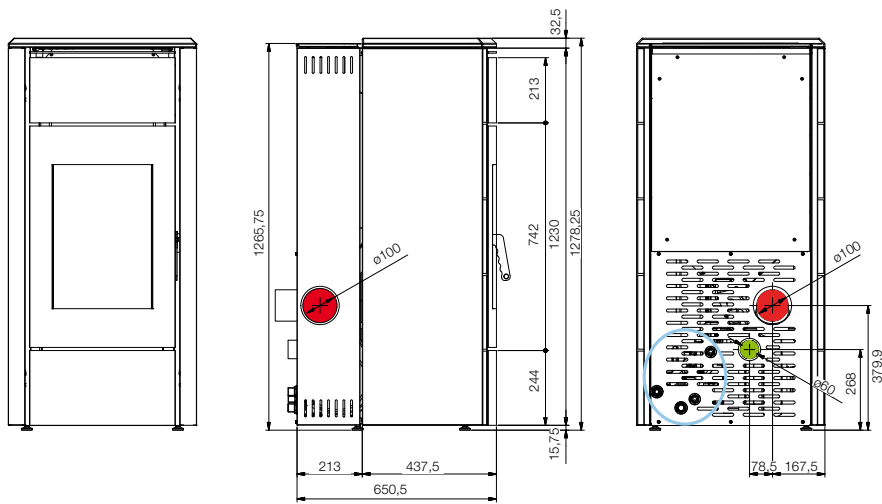

- Ingresso aria
Air inlet
- Uscita fumi
Smoke outlet
- Kit idraulico
3/4" per 20 kW
1" per 24 kW
Plumbing kit
3/4" for 20 kW
1" for 24 kW

BRERA

MAIOLICA

20 kW

24 kW

28 kW

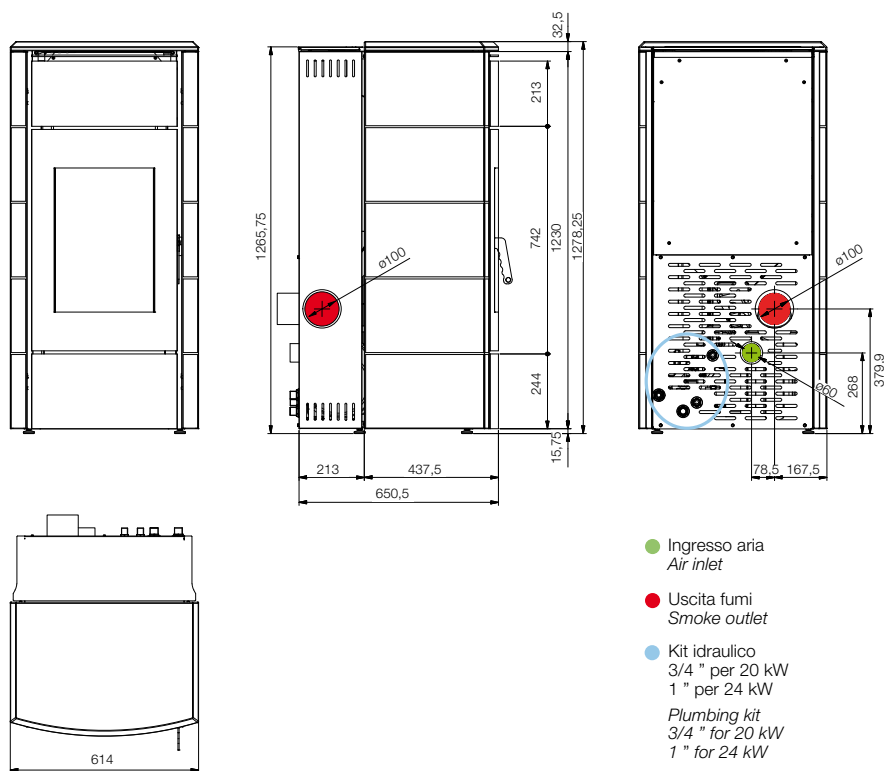

I-DEA

ANGOLO IDRO

17 kW

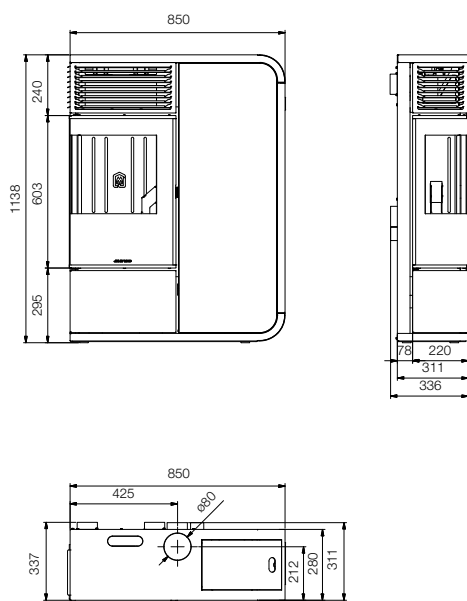

I-DEA

FRONTALE IDRO

17 kW

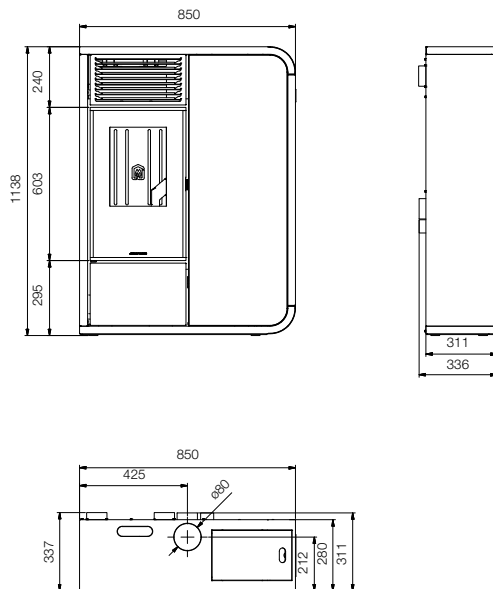

I-DEA

QUADRA IDRO

17 kW

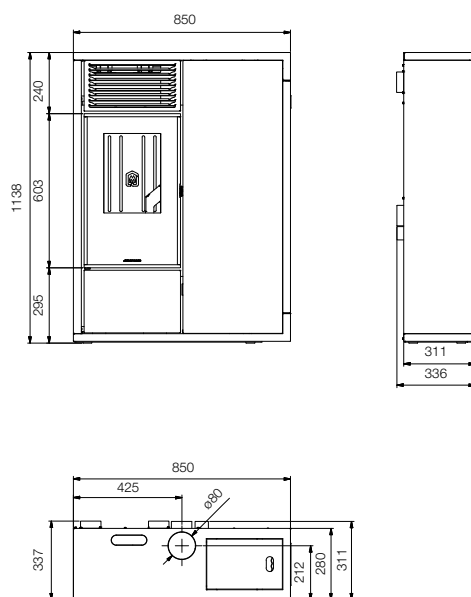

SYNTHESIS

MODULAR IDRO

21 kW

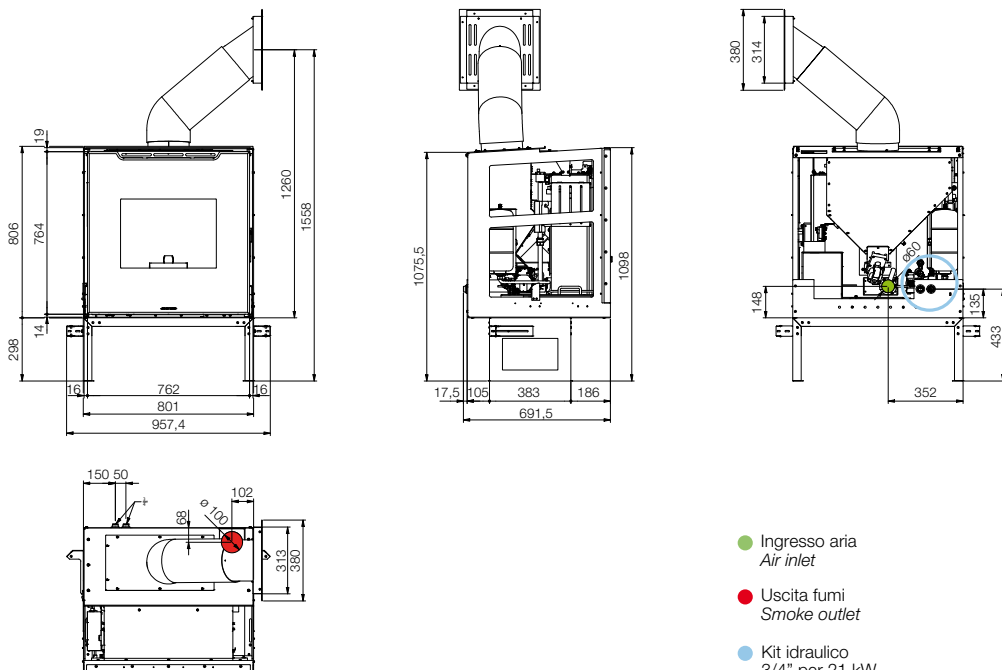

- Ingresso aria
Air inlet
- Uscita fumi
Smoke outlet
- Kit idraulico
3/4" per 21 kW
Plumbing kit
3/4" for 21 kW

J20 - J25

20 kW

25 kW

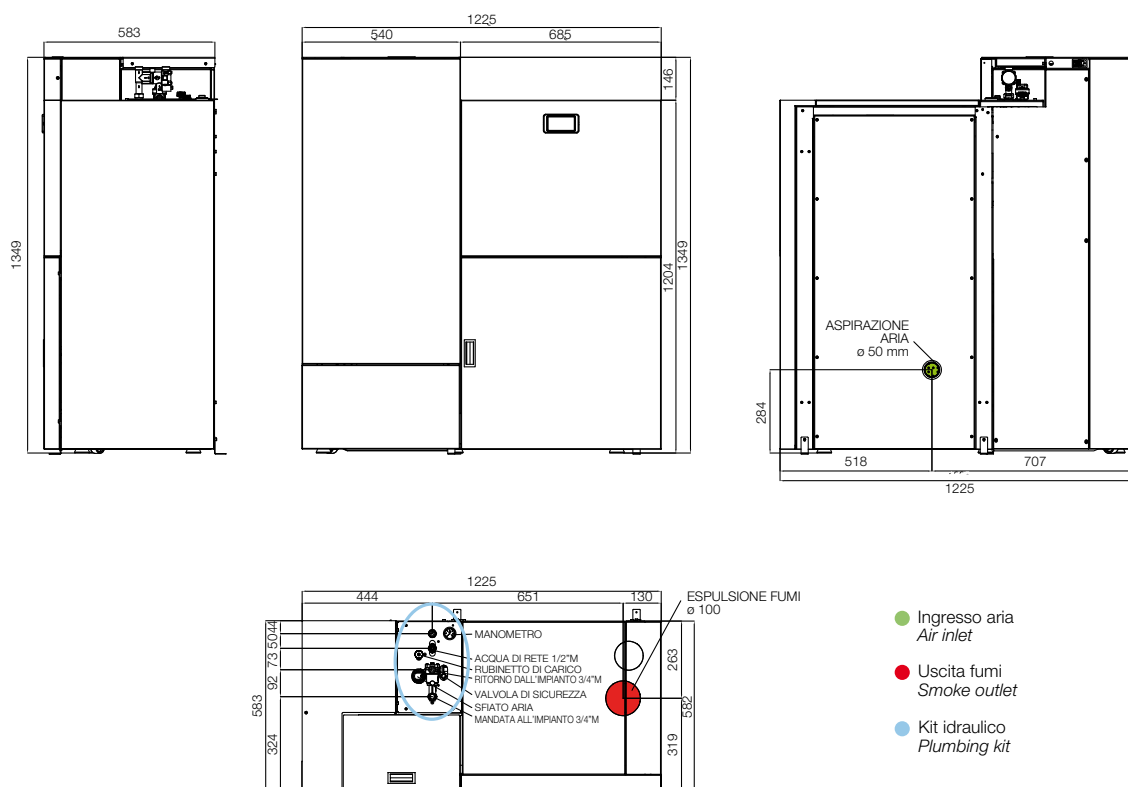

- Ingresso aria
Air inlet
- Uscita fumi
Smoke outlet
- Kit idraulico
Plumbing kit

J20 - J25

CON CONTENITORE SUPPLEMENTARE
WITH ADDITIONAL PELLET CONTAINER

20 kW

25 kW

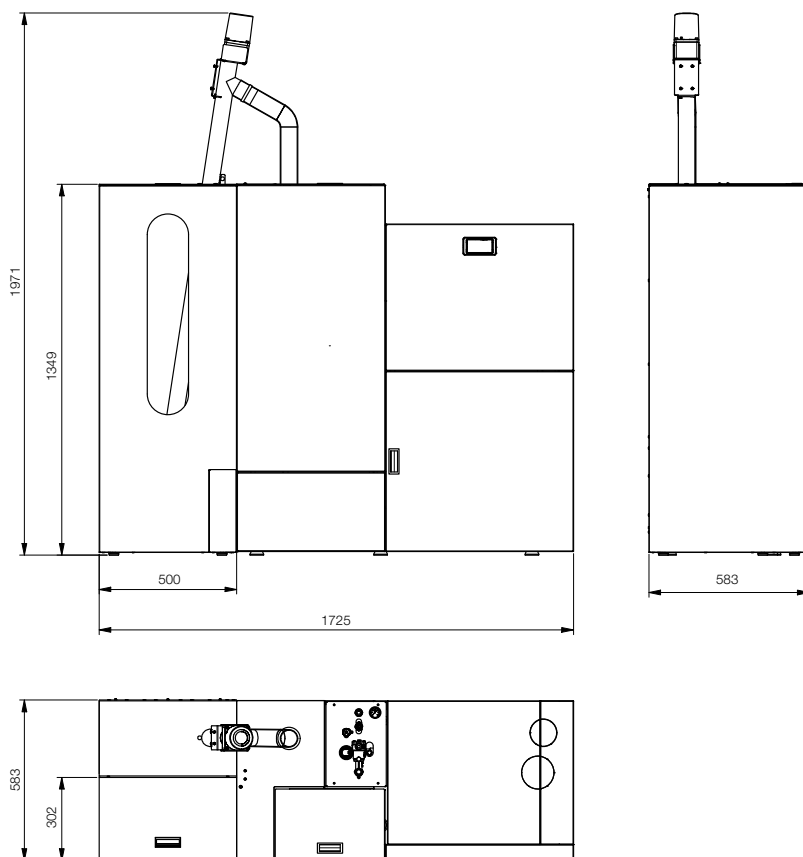

J30 - J35

30 kW

35 kW

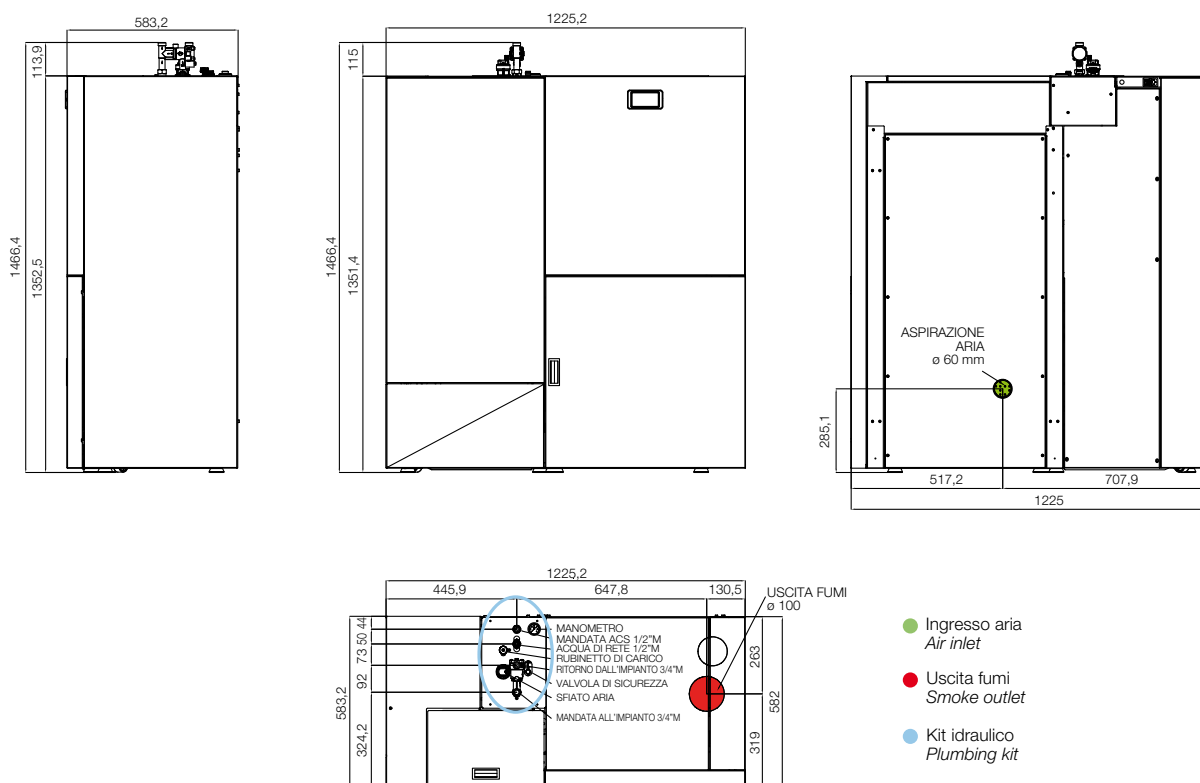

- Ingresso aria
Air inlet
- Uscita fumi
Smoke outlet
- Kit idraulico
Plumbing kit

J30 - J35

CON CONTENITORE SUPPLEMENTARE
WITH ADDITIONAL PELLET CONTAINER

30 kW

35 kW

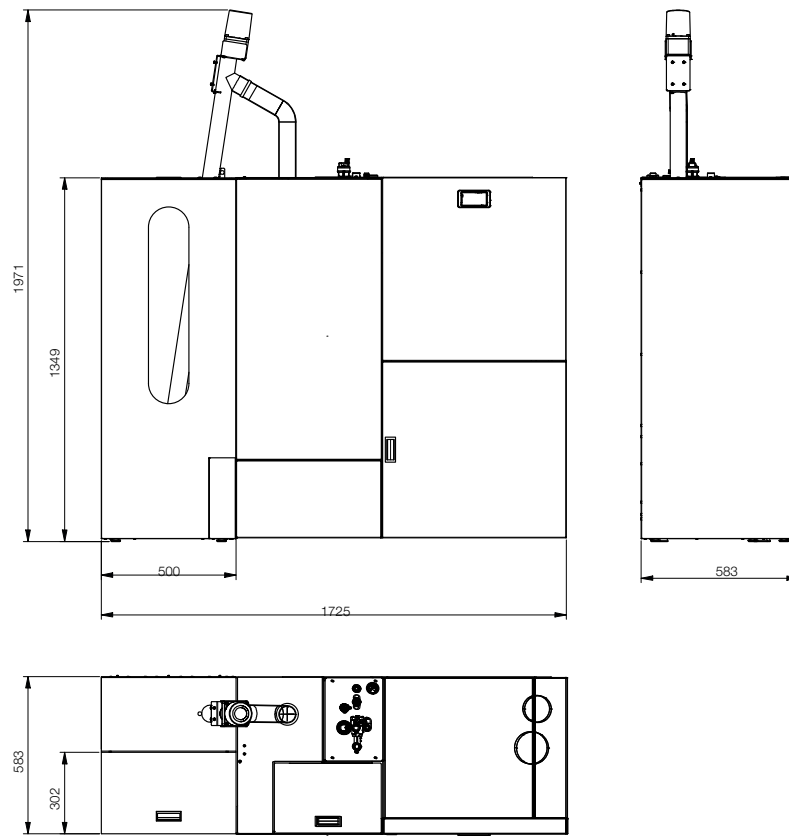

INCENTIVI CONTO TERMICO 2.0 2020
 ITALIAN INCENTIVE

Nome prodotto	Stelle ITA	Coefficiente premiante	ZONA A	ZONA B	ZONA C	ZONA D	ZONA E	ZONA F
V-SION - 8 kW	4	1,2	513,33	727,22	941,10	1.197,77	1.454,43	1.539,99
PIXIE - 7 kW	5	1,5	462,36	655,01	847,66	1.078,84	1.310,02	1.387,09
CHRISSIE - 6 kW	4	1,2	355,15	503,13	651,11	828,69	1.006,27	1.065,46
CULT - 8 kW	4	1,5	507,52	718,98	930,45	1.184,21	1.437,97	1.522,55
BOTERO2 - 8 kW	4	1,5	507,52	718,98	930,45	1.184,21	1.437,97	1.522,55
BOTERO2 - 10 kW	4	1,5	555,38	786,79	1.018,20	1.295,89	1.573,59	1.666,15
ODETTE - 6 kW	4	1,2	355,15	503,13	651,11	828,69	1.006,27	1.065,46
ODETTE - 8 kW	4	1,5	507,52	718,98	930,45	1.184,21	1.437,97	1.522,55
ODETTE - 10 kW	4	1,5	555,38	786,79	1.018,20	1.295,89	1.573,59	1.666,15
MELTEMI - 12 kW	4	1,5	479,49	679,27	879,06	1.118,80	1.358,55	1.438,46
MELTEMI - 14 kW	4	1,5	636,54	901,77	1.166,99	1.485,26	1.803,53	1.909,62
I-DEA2 ANGOLO - 10 kW	5	1,2	560,16	793,56	1.026,96	1.307,04	1.587,12	1.680,48
I-DEA2 FRONTALE - 10 kW	5	1,2	560,16	793,56	1.026,96	1.307,04	1.587,12	1.680,48
AMBRIA2 - 6 kW	4	1,2	358,19	507,44	656,68	835,78	1.014,88	1.074,57
AMBRIA2 - 8 kW	4	1,2	406,01	575,19	744,36	947,37	1.150,37	1.218,04
AMBRIA2 - 10 kW	4	1,5	555,38	786,79	1.018,20	1.295,89	1.573,59	1.666,15
PADDY - 6 kW	4	1,2	358,19	507,44	656,68	835,78	1.014,88	1.074,57
PADDY - 8 kW	4	1,2	406,01	575,19	744,36	947,37	1.150,37	1.218,04
PADDY - 10 kW	4	1,5	555,38	786,79	1.018,20	1.295,89	1.573,59	1.666,15

Nome prodotto	Stelle ITA	Coefficiente premiante	ZONA A	ZONA B	ZONA C	ZONA D	ZONA E	ZONA F
SYNTHESIS 60 - 7 kW	5	1,5	462,36	655,01	847,66	1.078,84	1.310,02	1.387,09
SYNTHESIS MODULAR 68 - 9 kW	5	1,5	530,51	751,55	972,59	1.237,85	1.503,10	1.591,52
SYNTHESIS MODULAR 80 - 11,5 kW	4	1,5	589,30	834,85	1.080,39	1.375,04	1.669,69	1.767,91
DUKA 4S - 16 kW	4	1,2	537,40	761,31	985,23	1.253,92	1.522,62	1.612,19
DUKA 5S - 19 kW	5	1,5	710,20	1.006,11	1.302,03	1.657,13	2.012,23	2.130,60
BRERA - 20 kW	4	1,2	582,82	825,66	1.068,51	1.359,92	1.651,33	1.748,46
BRERA - 24 kW	4	1,5	766,55	1.085,94	1.405,34	1.788,61	2.171,88	2.299,64
BRERA - 28 kW	4	1,5	803,73	1.138,61	1.473,50	1.875,36	2.277,23	2.411,18
I-DEA ANGOLO - 17 kW	4	1,5	683,37	968,11	1.252,85	1.594,53	1.936,22	2.050,11
I-DEA FRONTALE - 17 kW	4	1,5	683,37	968,11	1.252,85	1.594,53	1.936,22	2.050,11
I-DEA QUADRA - 17 kW	4	1,5	683,37	968,11	1.252,85	1.594,53	1.936,22	2.050,11
SYNTHESIS MODULAR IDRO - 21 kW	5	1,5	736,63	1.043,55	1.350,48	1.718,79	2.087,10	2.209,88
J20 - 20 kW	5	1,5	1.522,80	2.157,30	2.791,80	3.553,20	4.314,60	4.568,40
J25 - 25 kW	5	1,5	1.846,80	2.616,30	3.385,80	4.309,20	5.232,60	5.540,40
J30 - 30 kW	5	1,5	2.235,60	3.167,10	4.098,60	5.216,40	6.334,20	6.706,80
J35 - 35 kW	5	1,5	2.543,40	3.603,15	4.662,90	5.934,60	7.206,30	7.630,20

LEGENDA NORME E CERTIFICAZIONI / CERTIFICATION LEGEND:

EN 13240

La norma specifica i requisiti di progettazione, fabbricazione, costruzione, sicurezza e prestazioni (rendimento ed emissioni), istruzioni e marcatura, unitamente ai relativi metodi di prova per le prove di tipo delle stufe alimentate a combustibile solido. La norma si applica alle apparecchiature ad alimentazione non meccanica e non si applica alle apparecchiature con alimentazione di aria comburente assistita da ventola. *The standard specifies the requirements of the design, manufacture, construction, safety and performance (efficiency and emissions), instructions and marking together with associated test methods for type tests of solid fuel fired heaters. The standard applies to non-powered mechanical equipment and shall not apply to equipment with combustion air supply fan-assisted.*

EN14785

Norma Europea che specifica i requisiti relativi alla progettazione, fabbricazione, costruzione, sicurezza e prestazioni (efficienza ed emissioni), istruzioni e marcatura, oltre ai relativi metodi di prova e combustibili per la prova di tipo, per gli apparecchi per il riscaldamento a pellet, anche ad alimentazione automatica. *European standard that specifies requirements for the design, manufacture, construction, safety and performance (efficiency and emissions), instructions and marking, as well as relevant test methods and fuels for the type test, for equipment for the pellet heating, also automatically fed.*

EN 13229

Norma Europea che specifica i requisiti relativi alla progettazione, alla fabbricazione, alla costruzione, alla sicurezza e alle prestazioni (emissioni e rendimento), alle istruzioni e alla marcatura oltre ai relativi metodi di prova per la prova di tipo, per gli inserti e i termo camini alimentati a combustibile solido. *European standard that specifies requirements for the design, manufacture, construction, safety and performance (efficiency and emissions), instructions and marking, as well as relevant test methods and fuels for the type test, for the inserts and the fireplaces solid fuel-fired.*



Stufa ermetica certificata con DTA rilasciata dal CSTB. (Francia)
Airtight stove certified with DTA released by CSTB. (France)



I prodotti JOLLY MEC rispondono ai requisiti prescritti dalla normativa BlmSchV2 Tedesca.
The Jolly Mec products meets to the requirements prescribed by the German regulation BlmSchV2.



Incentivo erogato dal GSE per la promozione dell'energia termica da fonti rinnovabili, a seguito di sostituzione di determinate tipologie di impianti esistenti. (Italia)
Italian incentive that promotes the production of thermal energy from renewable sources.



Ordinanza contro l'inquinamento atmosferico. (Svizzera)
Ordinance against the atmospheric pollution. (Swiss)



Certificato svizzero di omologazione antincendio per apparati di riscaldamento e regolamento antimog.
Swiss fire certificate approval for heating equipment and antimog regulation.

4 STELLE



Classificazione art. 290, Italia. DM 186 del 7/11/2017
Classification art. 290, Italy



La marcatura CE indica che il prodotto è conforme a tutte le disposizioni comunitarie che prevedono il suo utilizzo: dalla progettazione, alla fabbricazione, all'immissione sul mercato, alla messa in servizio del prodotto. La marcatura CE disciplina l'intero ciclo di vita del prodotto dal momento dell'immissione sul mercato.

The marking CE indicates that the product conforms to all the Community provisions providing for its use: from design, manufacture, placing on the market, commissioning of the product until the disposal. The marking CE disciplines the full cycle of life of the product from its entry into the market.



Classe di Efficienza Energetica.
* Secondo una scala da G ad A++
Energetic Efficiency Class.
* *With a range from G to A++*



I nostri prodotti sono compatibili al regolamento 2015/1185 (Ecodesign). Il regolamento 2015/1185 introduce degli specifici criteri di progettazione e entrerà in vigore a partire dal 1 gennaio 2022.
Our products are compatible with the 2015/1185 regulation (Ecodesign). The 2015/1185 regulation introduces specific design criteria and will come into force starting from 1 January 2022.

EN 303-5

"Norma europea che specifica i requisiti relativi alla progettazione, fabbricazione, costruzione, sicurezza e prestazioni (efficienza ed emissioni), istruzioni e marcatura, oltre ai relativi metodi di prova e combustibili per la prova di tipo, per le caldaie a combustibili solidi con alimentazione manuale o automatica".

European standard specifying requirements relating to design, manufacture, construction, safety and performance (efficiency and emissions), instructions and marking, as well as related test methods and fuels for type testing, for solid fuel boilers with manual or automatic feed.



Scarica il catalogo



Download the catalogue



www.jolly-mec.it

RIVENDITORE AUTORIZZATO - AUTHORIZED RETAILER:

JOLLY-MEC CAMINETTI SpA

Via San Giuseppe, 2 - 24060 TELGATE (BG) ITALY

Tel. +39 035 8359211 - Fax +39 035 8359203 - info@jolly-mec.it

JOLLY MEC Caminetti SpA si riserva, senza preavviso, di variare le caratteristiche dei prodotti in qualunque momento per qualsiasi esigenza di carattere tecnico o commerciale. Si declina ogni responsabilità per eventuali errori, inesattezze e omissioni. Questo documento non può essere riprodotto, nemmeno parzialmente, senza autorizzazione scritta da parte di JOLLY MEC, proprietaria dei diritti. Le caratteristiche dei materiali (es. venature dei marmi o della maiolica) che non alterano le proprietà del prodotto, ma che possono discostarsi dalle venature e/o tonalità di colori rispetto alle foto riportate sui cataloghi JOLLY MEC Caminetti SpA, non sono considerate difetti.

JOLLY MEC Caminetti SpA reserves the right to change the features of its products at any moment in time, and without notice, for any requirements of a commercial or technical nature. The company declines all liability for errors, inaccuracies or omissions. The reproduction of this document, even partial, without written authorisation from JOLLY MEC Caminetti SpA, the owner of the rights, is strictly prohibited. The features of the materials (e.g. marble or ceramic veins) which do not alter the properties of the product, but simply differ from the veins and/or colours indicated in the photographs found in the JOLLY MEC Caminetti SpA catalogues, shall not be deemed as defects in material.



www.jolly-mec.it